

Easidew PRO XP

Explosion Proof Moisture Transmitter

The Easidew PRO XP transmitter is designed to reliably and accurately measure dew point or moisture content in a wide variety of gas or liquid process applications. The robust mechanical design minimises installation time and provides a robust and reliable transmitter for all global explosion and flameproof applications.



Highlights

- Measurement ranges -110 up to +20°Cdp
- Global explosion / flameproof certification
- Accuracy $\pm 1^{\circ}\text{Cdp}$
- 2-wire 4-20 mA output
- Traceable 13-point calibration certificate
- 450 bar pressure rating
- 3/4" UNF industry standard process connection
- EN 10204 3.1 material certification
- Moisture in gases and liquids
- Integral display meter
- Electronics Conformal Coating
- Oxygen Service Cleaned

Applications

- Natural gas processing / transmission
- Polymer production
- Biomethane gas production
- Hydrogen coolants
- LNG & LPG production
- Inert & bulk gases
- CNG production
- Hydrocarbon refinery processing
- Heat treating furnaces
- Catalyst protection



Easidew PRO XP

The Global Explosion Proof Transmitter

For OEM system integrators and process refineries there is a critical need to have one rugged transmitter in stock, which covers all their explosion proof system needs, irrespective of worldwide location.

The Easidew PRO XP moisture transmitter is ATEX, cCSAus, IECEx, and GOST globally certified within a single design for use in any North American, European or Asian zone, minimizing cost of stock ownership.

The transmitter has a wide dew-point measurement range of -110 to $+20^{\circ}\text{Cdp}$ with industry-standard process and electrical connections, ensuring low installation costs.

The Easidew PRO XP incorporates the latest Michell advanced ceramic technology providing stable and reliable measurements for all new and replacement moisture applications.

The unit can also be supplied with an integral 4 digit LED display, displaying the configured moisture output signal.

Ease of Installation

Our in-house design team have developed the product mechanics to ensure the unit can be quickly and economically installed.

- Electrical industry standard process housing with dual conduit entry
- US Industry Standard 3/4" UNF Viton® O-ring process connection
- On-site re-ranging and diagnostic communications tool
- 316 stainless steel transmitter sample block
- Transmitter mounting bracket
- 316 stainless steel housing for offshore applications (ATEX, IECEx & cCSAus approved)
- 316 Stainless Steel Tag

Global Certifications

The Easidew PRO XP uniquely has worldwide explosion and flameproof certifications to ensure a single unit has global acceptability.

- Explosion proof approval — cCSAus (US and Canada)
- Flameproof approval — ATEX
- Flameproof approval — IECEx
- Flameproof approval — TC TR Ex
- Canadian pressure vessel approved (CRN)
- EMC/RFI — 2014/30/EU EN 61326-1:2006

Safety and Integrity

The mechanical design considers the health and safety requirements of the end user offering an ultra-high process pressure barrier, along with meticulous levels of product traceability and quality.

- High performance 450 bar process media barrier
- No process media entry into the process housing
- Gas wetted parts BS EN 10204 3.1 material certified
- 13 point calibration certificate
- ISO 9001 quality system
- Electronics Conformal Coating
- Optional cleaning for enriched oxygen service

Measurement Performance

The transmitter uses Michell's market leading ceramic measurement technology coupled with the latest generation, sophisticated microcontroller electronics to provide accurate and stable measurement across the Easidew PRO XP product life.

- Accuracy $\pm 1^{\circ}\text{Cdp}$
- Fast response to moisture changes

Flexibility of Ownership

The Easidew PRO XP has a secondary RS485 communication system, which gives customers the opportunity to re-range and re-scale a unit for a variety of gas and non-polar liquid moisture measurements.

- Re-ranging 4–20 mA within the -110 to $+20^{\circ}\text{Cdp}$ range
- Moisture scaling — dew point, ppm_v , ppm_w

Speed of Supply

The transmitter is manufactured within Michell's world-leading high-volume moisture transmitter manufacturing center in the United Kingdom, which ensures reliability and repeatability of delivery and field supported by a network of Michell's global service centers.

- Calibration manufacturing system is traceable to NPL and NIST standards

Integral Display

The Easidew PRO XP EX2 has an integral display meter providing local indication of the transmitted analog output in the configured moisture scale.

System Customization

If your application requires a customized sensor solution, we have a specialized design and manufacturing capability to cover your requirements.

Technical Specifications

| Performance Specifications | Easidew PRO XP for Gases | Easidew PRO XP LQ for Liquids |
|--|---|--|
| Measurement range | -110 to +20°C dew point; -100 to +20°C dew point | 0 to 1000 ppm _w ; Non-standard available on request |
| Accuracy | ±1°C dew point (+20 to -60°C); ±2°C dew point (-60 to -110°C) | |
| Response time | 5 mins to T95 (dry to wet) | |
| Repeatability | 0.5°C dew point | |
| Calibration | Traceable 13 point calibration and certificate | |
| Electrical Specifications | | |
| Output signal | 4-20 mA (2-wire connection, current source); User configurable over range | |
| Output | Dew point or moisture content | Moisture content |
| Analog output scaled range | Dew point: -110 to +20°C; Moisture content in gas: 0-3000 ppm _v , Non-standard : mg/m ³ , lbs/MMSCF natural gas | Moisture content in liquid: 0-1000 ppm _w Non-standard available upon request |
| Supply voltage | 14 to 28 V DC | |
| Load resistance | Max 250 Ω @ 14 V (500 Ω @ 24 V) | |
| Current consumption | 23 mA max, depending on output signal | |
| Saturation constants (for moisture in liquids measurements only) | 6-point look-up table for saturation constants up to 1000 ppm _w over the temperature range 0 to +50°C; saturation constants for 8 common liquids can be programmed into the Easidew PRO XP LQ via the application software; alternatively the user can program saturation constants manually | |
| CE conformity | Approved | |
| Operating Specifications | | |
| Operating temperature | -40 to +60°C | |
| Compensated Temperature Range | -20 to +50°C NOTE: The transmitter accuracy statement is only valid for the temperature range: -20/+50°C | |
| Storage Temperature | -40 to +60°C | |
| Operating pressure | 45 MPa (450 barg) maximum | |
| Flow rate | 1 to 5 NI/min mounted in standard sampling block; 0 to 10 m/sec direct insertion | 0.1 to 0.3L/min through Easidew sample block 0.1 to 1m/s direct insertion |
| Mechanical Specifications | | |
| Ingress protection | IP66 in accordance with standard BS EN 60529:1992; NEMA 4 protection in accordance with standard NEMA 250-2003 | |
| Explosion and flameproof area certificates | <p>ATEX: Standard: Aluminium II 2 GD Exd [ia] IIC T6 Gb Ex tb IIIC T80°C Db IP66 Tamb -20°C to +70°C</p> <p>IECEX: Exd [ia] IIC T6 Gb Ex tb IIIC T80°C Db IP66 Tamb -20°C to +70°C</p> <p>cCSAus: CLS I, Div1, GRPS ABCD CLS II & III, Div1, GRPS EFG CLS I, Zone 1 AEx/Exd [ia] IIC T6</p> <p>INMETRO (Brazil): Zone 21, AEx/Ex tb IIIC T80°C Tamb = -20°C to +70°C IP66 [Approval codes as per IECEX]</p> | <p>Optional: 316 stainless steel II 2 GD Exd [ia] IIC T6 Gb Ex tb IIIC T80°C Db IP66 Tamb -20°C to +70°C</p> <p>Exd [ia] IIC T6 Gb Ex tb IIIC T80°C Db IP66 Tamb -20°C to +70°C</p> <p>CLS I, Div1, GRPS ABCD CLS II & III, Div1, GRPS EFG Tamb = -20°C to +70°C IP66</p> <p>TC TR EX-Certifi cate: 1Ex d [ia] IIC T6 Gb X Ex tb IIIC T80°C Db X Tamb -20°C to +70°C (Russia, Belarus, Kazakhstan)</p> |
| Russian pattern approval | Pending: Russia (GOST-R), Kazakhstan (GOST-K) | |
| Canadian pressure vessel cert | C.R.N. - all Canadian provinces | |
| Oxygen service | Optional: Cleaned for enriched oxygen | |
| Housing material | Standard: Aluminium (copper free), epoxy and polyurethane powder coated, blue RAL 5009 Optional: 316 stainless steel (supplied with BS EN 10204 3.1 material certificate if option F2 requested) (ATEX, IECEX & cCSAus) | |
| Housing moisture protection | Optional: Electronics Conformal Coating | |
| Filter (sensor protection) | Standard: Stainless steel sintered guard (for protection against fine particulate >80µm) Optional: HDPE guard (for protection against fine particulate >10µm) | |
| Process connection and material | 3/4" — 16 UNF with recessed Viton® O-ring; 316 stainless steel | |
| Weight | Aluminium: 1.6kg; 316 stainless steel: 2.4kg | |
| Electrical connections | Dual 3/4" NPT gland | |
| Programmable display meter range | Optional: -1999 to +9999 | |
| Programmable display decimal point | Optional: 0 to 3 decimal places | |
| Display meter overload limits | Optional: 3.6 mA and 20.4 mA | |
| Programmable display meter scales | Optional: °C, °F, %, No Scale | |
| Stainless Steel tags | Optional: 316 stainless steel tags (70 x 25mm) | |
| Diagnostic conditions (factory programmed) | Conditions: Sensor fault, Under-range dew point, Over-range dew point | Output: 23 mA, 4 mA, 20 mA |

Easidew PRO XP

Product Dimensions

Easidew PRO XP Display

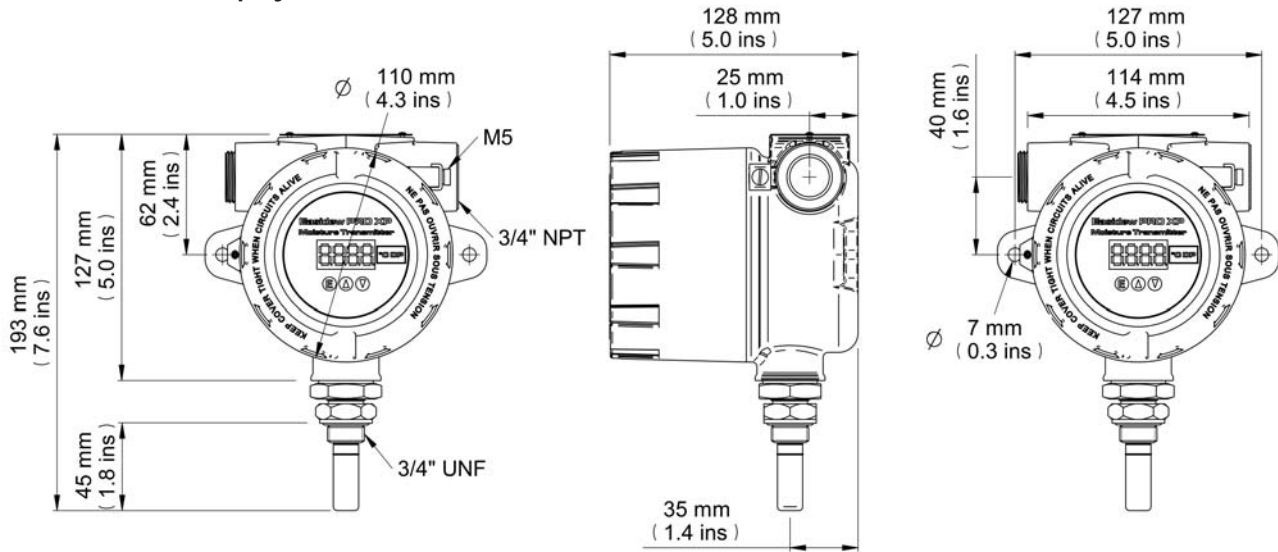

Easidew PRO XP

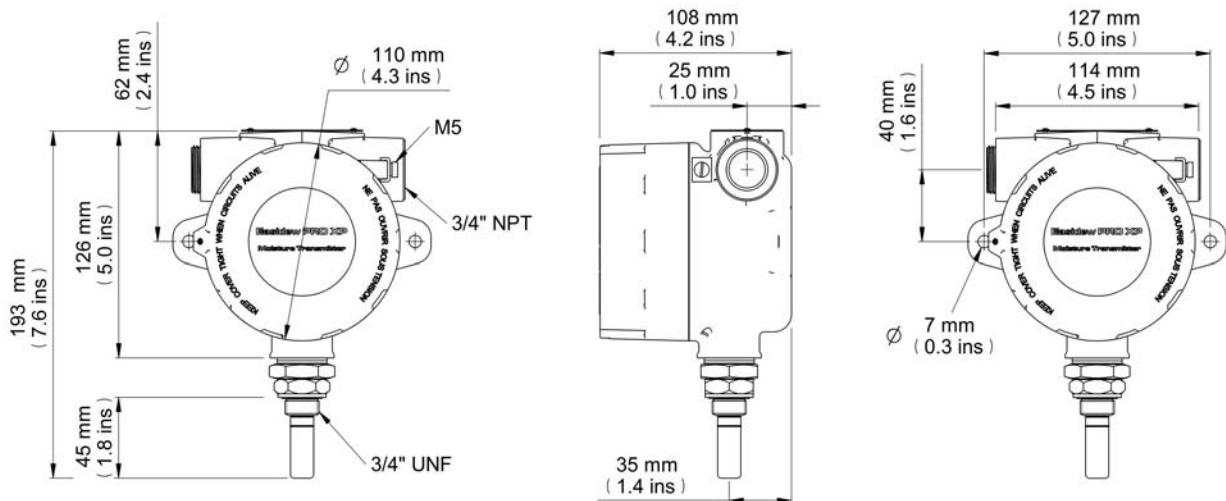

Related Process Products



Easidew PRO I.S.
I.S. Dew-Point Transmitter



MDM300 I.S. Portable
Dew-Point Hygrometer



Promet EExd
Process Moisture Analyzer



XTP601
Oxygen Analyzer



ES70
Sampling System

Michell Instruments Ltd, Rotronic Instruments Corp. 135 Engineers Road, Suite 150, Hauppauge NY 11788
Tel: 631 427 3898, Email: us.info@michell.com, Web: www.michell.com/us

Michell Instruments adopts a continuous development programme which sometimes necessitates specification changes without notice.
Issue no: Easidew PRO XP_ 97459_V6_US_0518