

LONG FLARE VERSION WITH STANDARD BRACKET

2-17/32" / 64.5±1mm (POS. 1 & 2)
2-43/64" / 68.0±1mm (POS. 3)

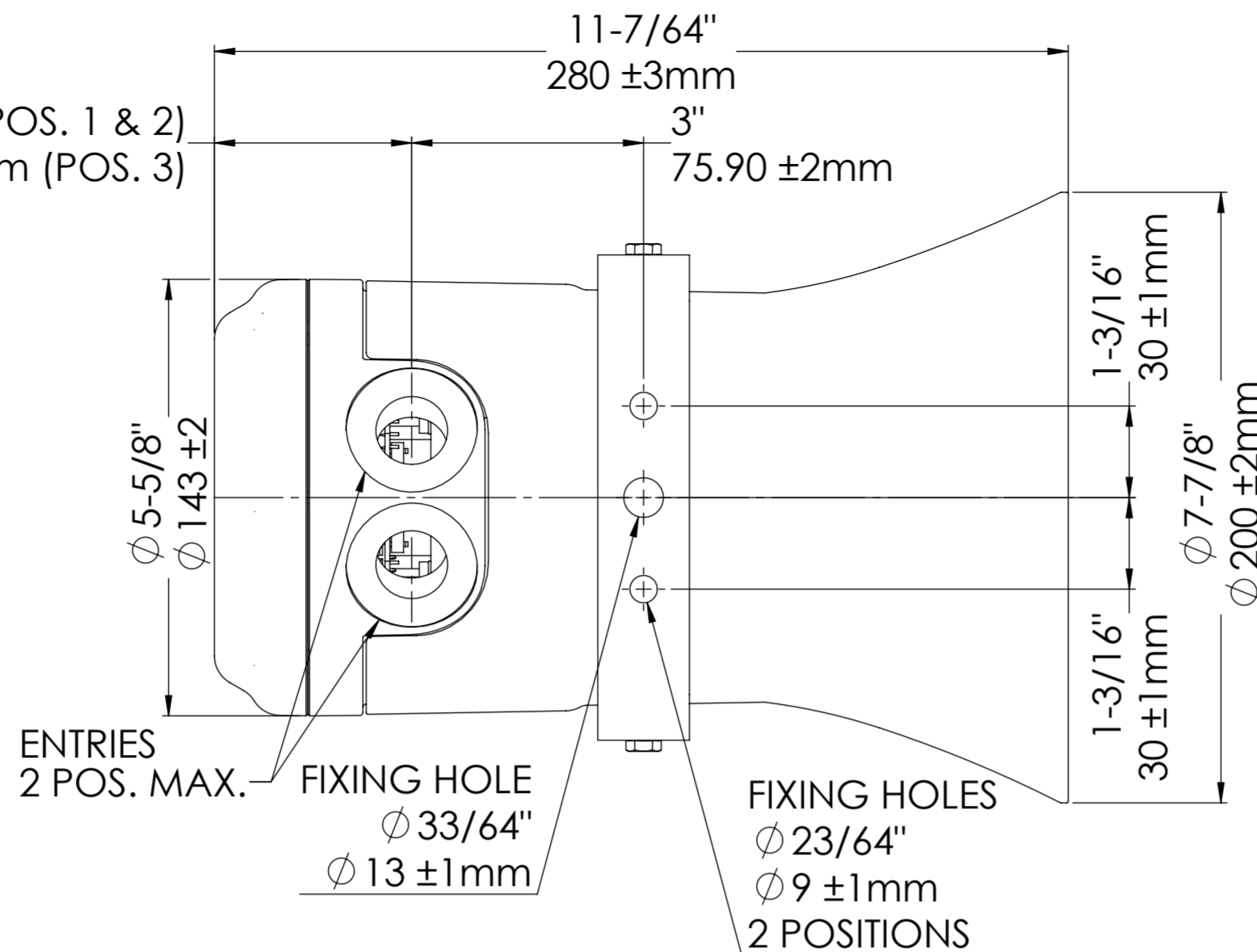
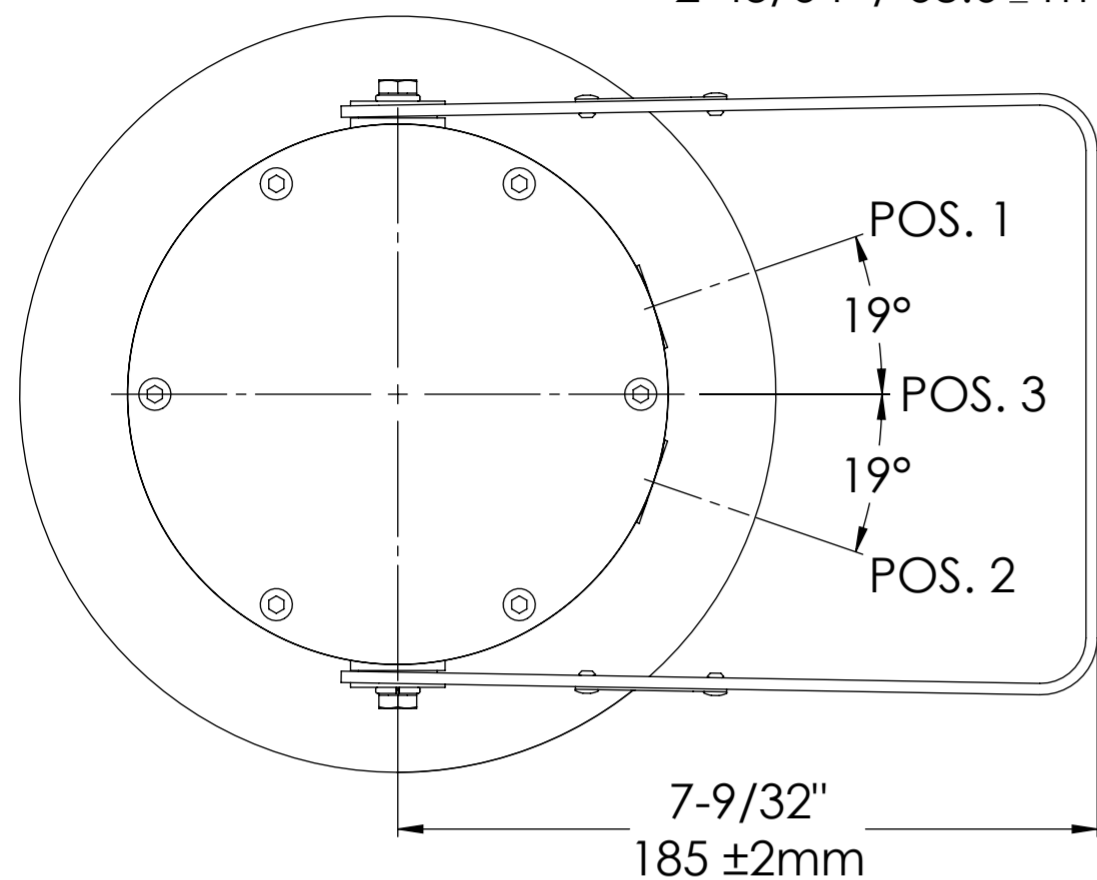

NOTES:

- 1/ UNIT TYPE: DB3B HORN - AUDIBLE SIGNAL DEVICE
- 2/ CERTIFICATION:
HAZARDOUS LOCATIONS UL LISTING No. E203310
SUITABLE FOR USE IN:
Class I, Zone 1 Ex d IIC / AEx d IIC Gb
Zone 21 Ex tb IIIC

Class I, Div. 2 Groups A, B, C, D
Class II, Div. 2, Groups F & G
Class III, Div. 1

ORDINARY LOCATIONS UL LISTING No. S8116
SUITABLE FOR FIRE ALARM OR GENERAL USE
- 3/ AMBIENT TEMPERATURE RANGE AND T-RATINGS:
T4/T135°C (-67°F TO +158°F)
T5/T100°C (-67°F TO +131°F)
T6/T85°C (-67°F TO +104°F)
- 4/ WEIGHT: - Ex d UNITS - DC: 10.2lbs, AC: 11lbs
- 5/ ENCLOSURE AND COVER MATERIAL: GLASS REINFORCED POLYESTER
- 6/ MAIN FLARE MATERIAL: FLAME RETARDANT THERMOPLASTIC POLYESTER
- 7/ STIRRUP AND COVER FIXINGS: STAINLESS STEEL GRADE 316
- 8/ OPTIONAL DUTY/TAG LABELS, LETTER SIZE 3/16" MAX.
- 9/ TERMINALS ARE SUITABLE FOR UP TO 14AWG MAX.
- 10/ CABLE ENTRIES: UP TO 2xM20 OR 2x1/2" NPT IN POSITIONS SHOWN.

FOR UNITS WITH 2 ENTRIES, POSITIONS 1 AND 2 ARE USED. FOR UNITS WITH A SINGLE ENTRY, POSITION 3 IS USED.

BLANKING PLUGS ARE AVAILABLE.
- 11/ ALL DIMENSIONS ARE COMMON TO ALL UNIT VARIATIONS UNLESS OTHERWISE STATED.
- 12/ GENERAL TOLERANCE: 1/32" UOS

SHORT FLARE VERSION WITH OPTIONAL SWIVEL BRACKET

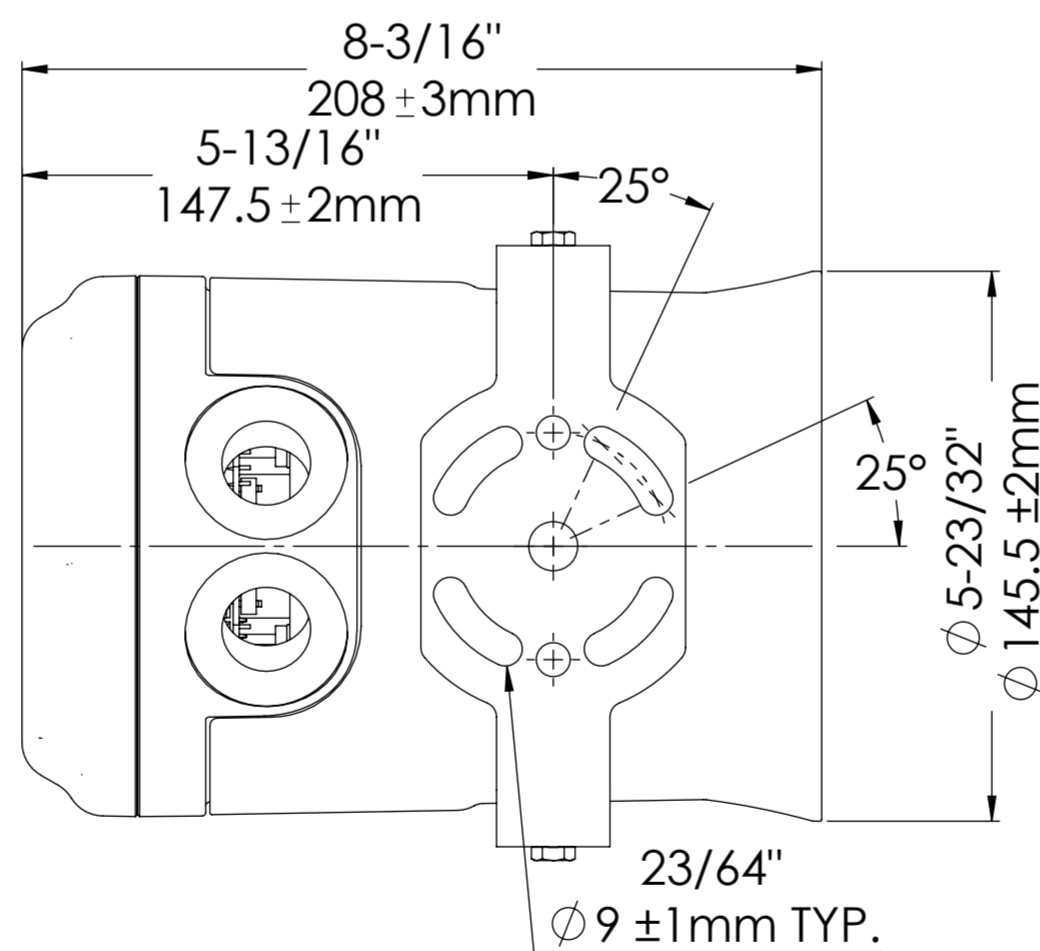
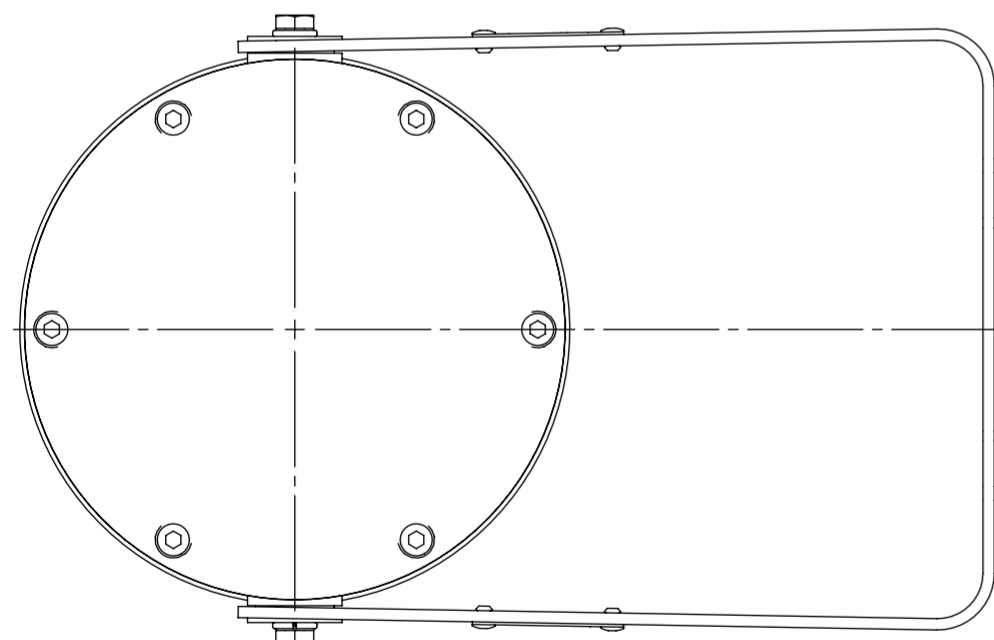

ISSUES

ALL DIMENSIONS ARE IN MILLIMETRES UNLESS OTHERWISE STATED
REMOVE ALL BURRS AND SHARP CORNERS
MACHINE SYMBOLS THUS ✓

THIS DRAWING IS CONFIDENTIAL AND IS THE PROPERTY OF MEDC AND MUST NOT BE REPRODUCED EITHER WHOLLY OR PARTLY. ALL RIGHTS IN RESPECT OF PATENTS, DESIGNS AND COPYRIGHT ARE RESERVED

		COOPER MEDC Ltd. UNIT B, SUTTON PARKWAY ODDICROFT LANE SUTTON-IN-ASHFIELD, NG17 5FB. U.K. Tel: +44 (0)1623 444400 Web: WWW.COOPERMEDC.COM		DESIGNERS & MANUFACTURERS OF ELECTRICAL & ELECTRONIC EQUIPMENT & SYSTEMS FOR HAZARDOUS AREAS	
		DRAWN BY: P.FISHWICK	DATE: 23/01/2015	TITLE: DB3B HORN UL CUSTOMER GA	
CHECKED BY: D.COATES	DATE: 23/01/2015	DWG NO.: 419-233		REVISION A	
APPROVED BY: P.FISHWICK	DATE: 23/01/2015	SCALE: 1:2 A2			