



Detcon

SENSOR DUCT MOUNT KIT

ISO 9001: 2000
Certified

888-367-4286
713-559-9200
fax 281-292-2860
www.detcon.com
sales@detcon.com

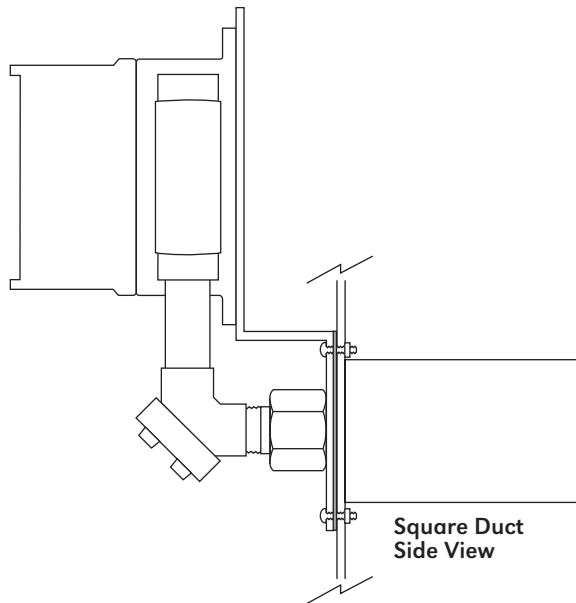

DESCRIPTION

The Detcon Sensor Duct Mount Kit allows a Detcon gas sensor assembly to be mounted so that its sensor is located inside of an air duct, while its transmitter, located outside the duct, is still accessible for calibration and other adjustments. This method of installation is much more economical than the typical sample draw type system that is normally used in such applications.

In operation, air flow through the duct enters the duct mount chamber through ports facing the oncoming flow of air. Once inside the chamber the sample passes by the sensor and then exits through similar ports that face the opposite direction. If any target gas is present in the chamber, the sensor output signals and/or alarm functions, will respond accordingly.

FEATURES

- ▶ Adaptable to square & round ducts
- ▶ In-situ calibration port
- ▶ Sensor readily serviceable
- ▶ One year warranty

ORDER GUIDE

Sensor Model Series	PN for Square Kit	PN for Round Kit
700	975-000020-893	975-R00020-893
FP (400/500/600)	975-000020-890	975-R00020-890
TP (400/500/600)	975-000020-891	975-R00020-891
DM (400/500/600)	975-000020-892	975-R00020-892
IR (500/600)	975-000208-91R	975-R00208-91R

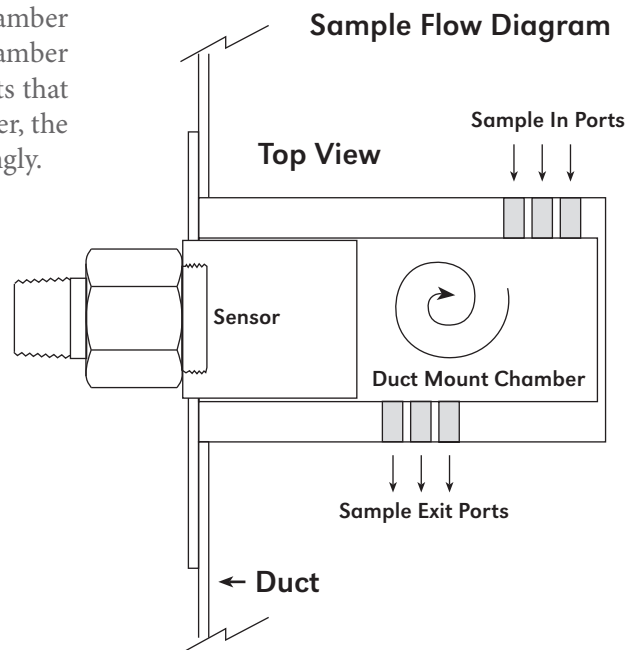

www.detcon.com