

# Pneumatic Horn PH 1

**High-intensity signalling device  
for long distances**

- ▶ Volume approx. 135 dB(A)
- ▶ Operated with compressed air, carbon dioxide or other gases
- ▶ Housing of impact-resistant plastic

## Application

Pneumatic horns are used wherever extremely loud signals are required and there is no power supply available. One possible application is in railway track construction to warn personnel of approaching trains. Since the signal has to travel long distances, the maximum volume of the PH 1 pneumatic horn of approx. 135 dB(A) is needed here.

## Design

Sturdy, corrosion-resistant construction for operation with compressed air or gases. The pressure needed ranges from 2 to 5 bar. The air consumption at standard set-up is approx. 5 litres/second. The scope of supply includes an air filter and a fastening angle. Not included are leads and threads. Magnetic valves are available as accessories for electric switching on of the device.

## Warning equipment for railway track maintenance

Pneumatic horns are used wherever extremely loud signals are required and there is no power supply available.



## Technical specifications

Housing	Impact-resistant plastic
Volume	Approx. 135 dB(A), 1 m (Regarding volume specifications, please see the chapter "Technical Informations".)
Frequency	400 Hz
Air consumption at standard set-up	Approx. 5 litres/sec.
Weight	Approx. 0.34 kg
Temperature range	-20°C to +40°C
Operating range	2 to 12 bar

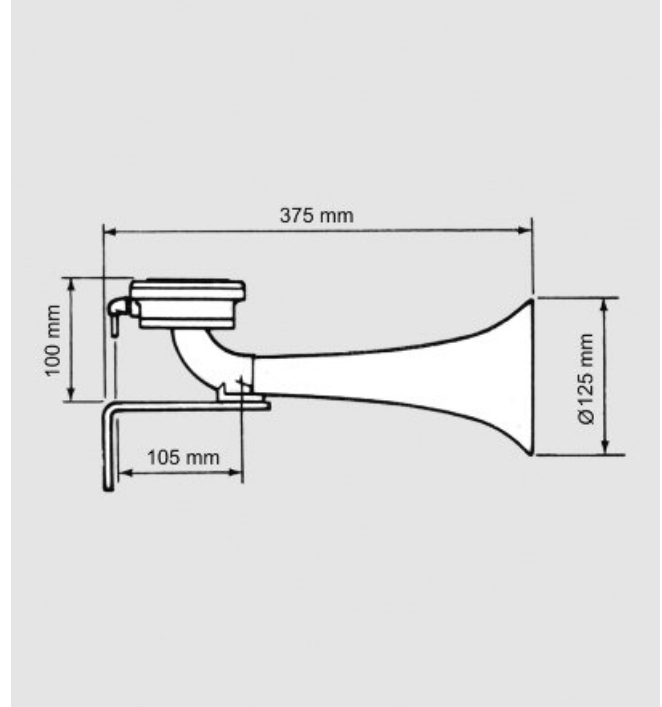

### Scope of supply:

The scope of supply includes a fastening angle and an air filter. Not included in the scope of supply are leads and threads.

## Order information

Type	Name	Rated voltage in V	Rated current in mA	Article no.
PH 1	Horn			216 001 01

### Accessories

XZG 1108	Magnetic Valve	230 VAC	8 VA	218 601 01
XZG 1108	Magnetic Valve	24 VDC	5 W	218 601 02

Subject to change without notice · Printout 12/10