

NEMA Classification of MCC & Wiring Requirements

Shahid Sheikh, P.E., SM - IEEE

Senior Specification Engineer – GE Energy

A low voltage motor control center is a group mounting of individual motor starters, feeder **O**ver Current Protective Devices (OCPD), Adjustable Frequency Drives (AFDs), Reduce Voltage Solid State Starters (RVSS), lighting panels and small distribution transformers in a metal enclosure including power and control bus. The control wiring requirements for MCC could be simple to very complex depending on the application environment and specification prepared by a specifying engineer. To understand the complexities and to correctly specify wiring requirements; this article describes different NEMA classification of motor control center, various types of wiring and their definition.

A motor control center (MCC) could be either Class I or Class II; it may be supplied with standard or custom drawings. When a motor control center supplied with custom drawings, it is either Class IS or Class IIS, simply adding a letter “S” at the end of its class indicates that custom drawings requirement.

NEMA Classes:

The following are various NEMA classifications of MCC and their definitions:

- NEMA Class I
- NEMA Class II
- NEMA Class IS
- NEMA Class IIS

NEMA Class I

In this class, combination of motor controllers and feeder over current protective devices (OCPD) are located in a convenient assembly, a bus-bar system supplies power to a contactor and over load relay, through a main disconnect. Overall dimensions, identification of units, location of incoming line terminals are provided but there is no inter wiring or interlocking between units or remote mounted devices. In this type of NEMA class of motor control center, manufacturer provides only individual unit’s diagram. This type of motor control centers recommended for small projects, where a limited number of starts are involved.

NEMA Class II

Class II motor control center is same as class I, except it includes all necessary interlocking and inter wiring between the units, it also provides remote interlocking. Manufacturer provides drawings indicating all necessary interconnections.

NEMA Class IS

This class is same as Class I, except in this class specifying engineer specifies custom drawings requirement, which are provided by the manufacturer.

NEMA Class IIS

This class is same as Class II, except in this class specifying engineer specifies custom drawings requirement, which are provided by the manufacturer.

Example of custom drawings; where special identification of devices, special terminal numbering or designation and special drawing size is required by a specifying engineer.

NEMA Classification of Wiring:

NEMA further subdivides motor control centers based on various wiring classes. According to NEMA standard ICS 18-2001 (R2007), there are three different types of wiring:

- type A Wiring
- type B wiring
- type C wiring

Type A wiring

In this type of wiring, both power and control cables from outside of a motor control center are directly connected to the device terminals inside a combination starter or feeder units. No terminal blocks are provided for either power or control cables. This type of wiring is only provided in class I motor control centers.

Type B wiring

In this type of wiring, combination starters in a motor control center are equipped with control terminal blocks. All the control wires from a combination starter are connected within a unit to marked terminals on a terminal block. The user brings field control wiring, if required, into each combination starter unit inside a motor control center and connections are made at each marked terminal block.

In 1994, NEMA standards ICS 18-2001(R2007) subdivide type B wiring into two categories:

- Type B-D
- Type B-T

Type B-D – In this case, the combination starters power cables are directly connected to an over load relay's terminals and feeders power cables are connected to an over current protective device terminal.

These devices should be located immediately adjacent to vertical wire-ways and should be readily accessible.

Type B-T – Power cables are connected to a power terminal block, which should be located immediately adjacent to vertical wire-way and should be readily accessible.

The combination starters size 1 through 4 are offered as type B-D as standard, and type B-T as optional. The size 5 and size 6 starters are always offered as type B-D. Adjustable Frequency Drives (AFDs), Reduce Voltage Solid-State Starters (RVSS) and multi-winding motor starters are offered as type B-T.

Type C Wiring

In this type of wiring, the user connects the field control wiring to a master terminal block, mounted in the horizontal wire-way, at top or bottom of a vertical section. The control wiring from each combination starter's terminal block to a master terminal block, mounted at either top or bottom, is done at the factory.

In this type of wiring, power cables from the field brought into horizontal wire-way at top or bottom of each vertical section and connected to master power terminal block. This Master Power Terminal Block is pre-wired to each combination starter unit at factory. In case of combination-starters larger than size 3, the user brings power cable directly into a starter unit instead of master terminal block; Power cables are directly connected to load terminal of overload relay.

NEMA Classification for MCC and types of wiring: When specifying a motor control center, a class I or a Class II MCC, could be combined with different types of wiring. Following are various combinations of different NEMA classes of MCC with different types of wiring.

1. Class -IA
2. Class -IB
3. Class- IC
4. Class -IIB
5. Class -IIC
6. Class -ISA
7. Class-ISB
8. Class-ISC
9. Class-IISB
- 10. Class-IISC**

Class I A

- Provides only power wiring from disconnect to a starter.
- Provides no control wiring and no interlocking.
- No terminal blocks are provided.

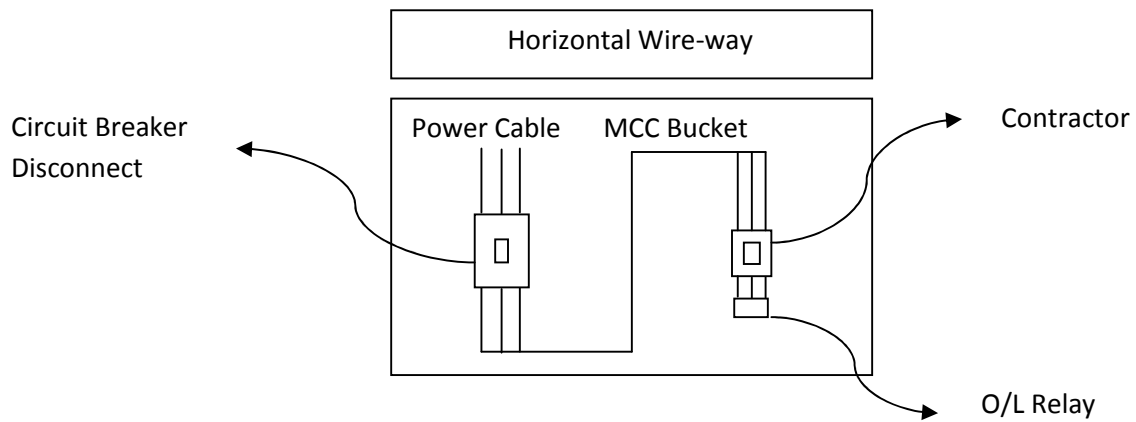

Figure 1

Class IC

- Master terminal blocks are installed at either top or bottom of each vertical section in horizontal wire-way.
- The wiring from a bucket's terminal block to master terminal block is completed at the factory.
- The user makes all fields wiring connection at mater terminal block.

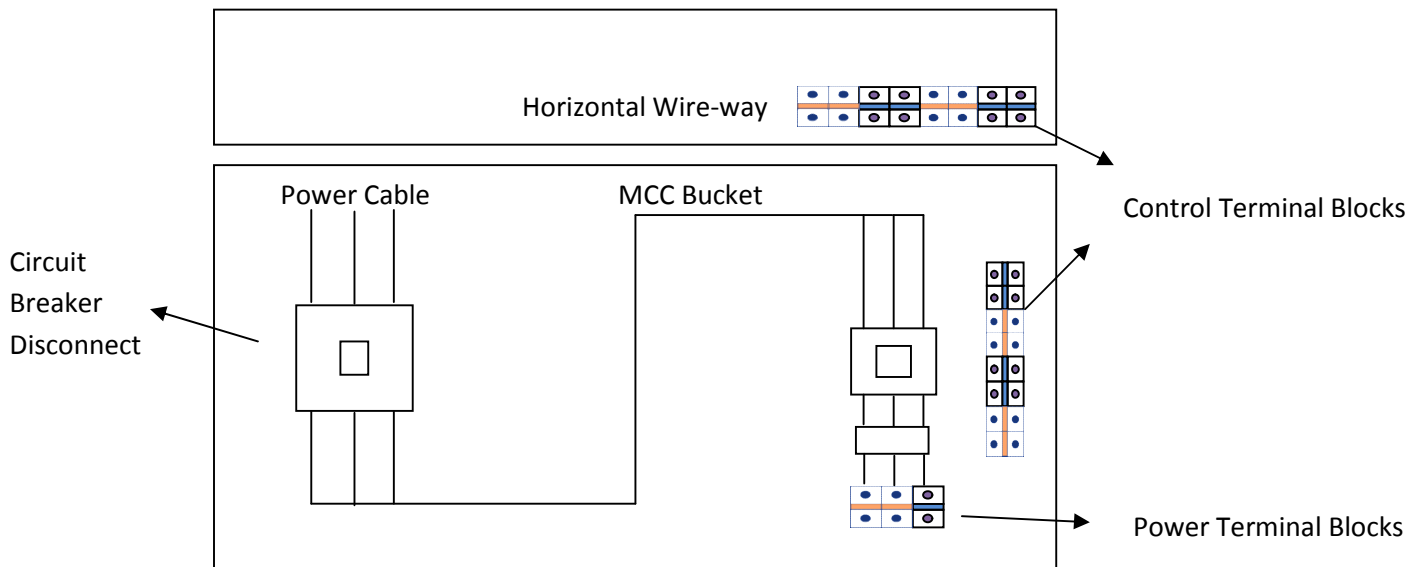

Figure 3

Class IIB

Class IIB wiring is similar to class IB except interconnecting wiring between motor starters in the same or different vertical sections is done at the factory.

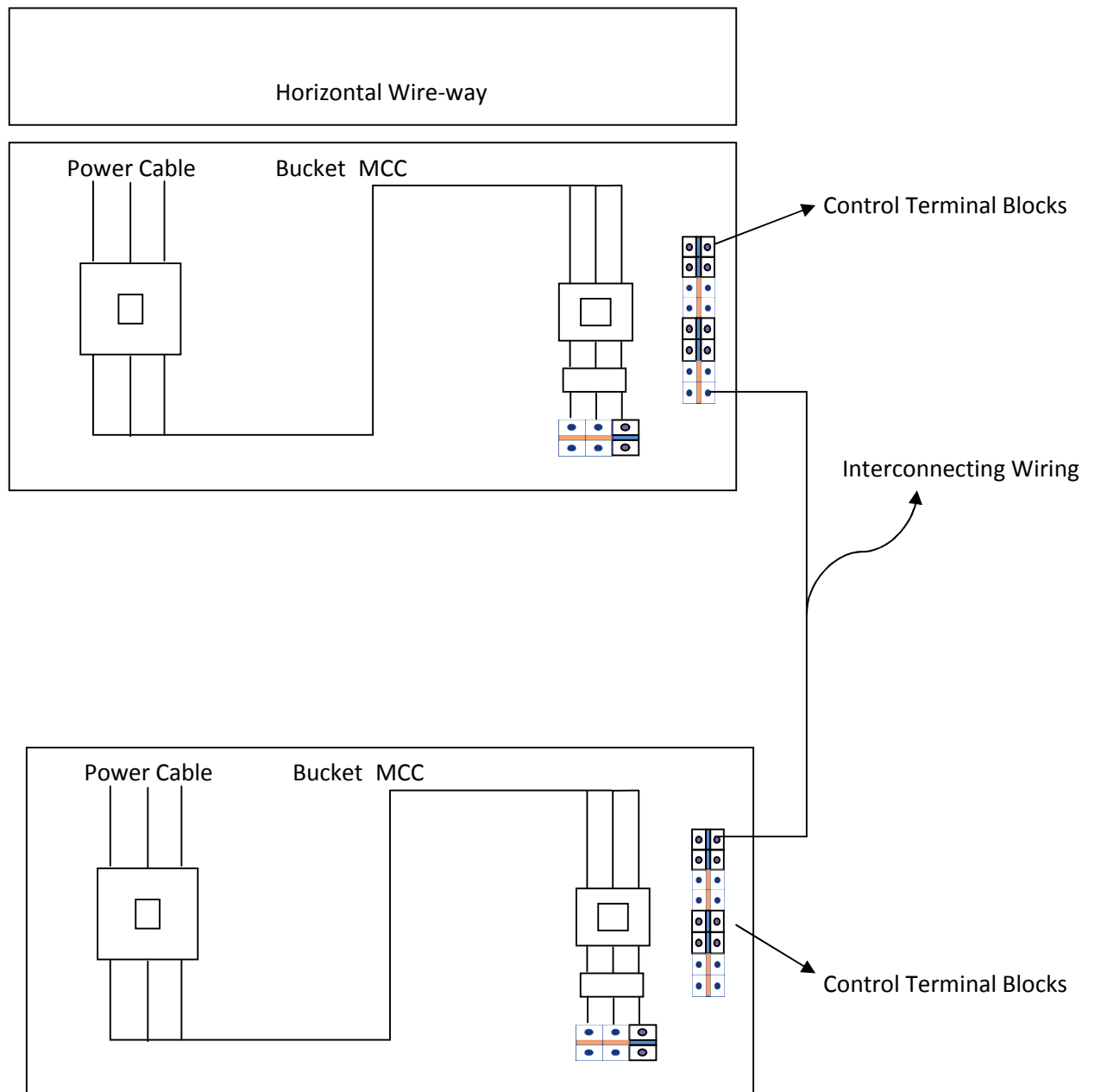

Figure 4

Class IIC

Class IIC wiring is similar to class IIB except a master terminal block either at the top or bottom of each vertical section is provided.

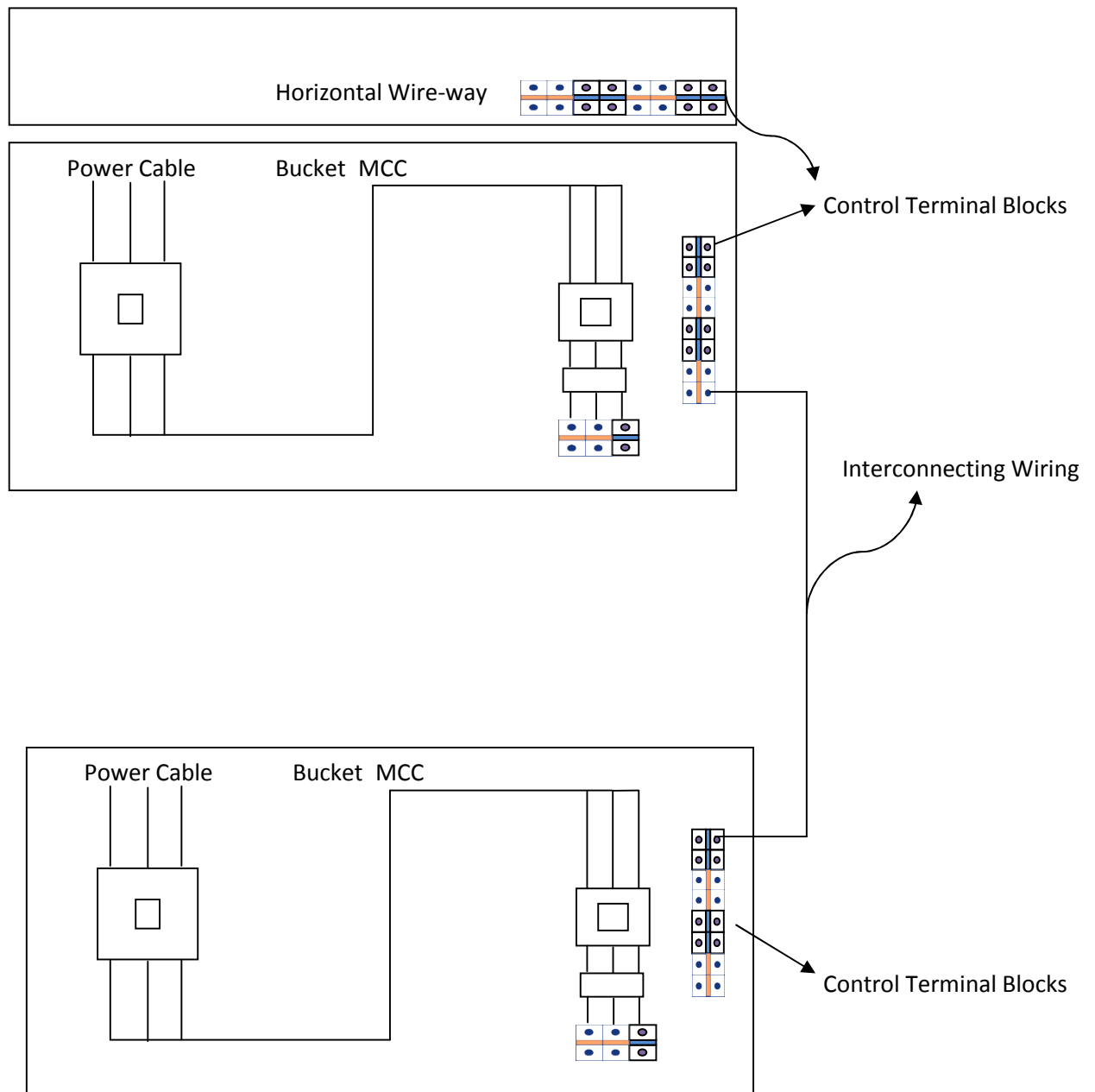

Figure 5

In Class ISA, ISB, ISC, IISB and IISC letter S indicates the requirement of custom drawings specified by a specifying engineer, all other requirements are the same as described for respective classes.

The following table summarizes all the NEMA classes and types of wiring for motor control center.

Type of Power or Control Termination Furnished	Class I			Class IS			Class II		Class IIS	
	A	B	C	A	B	C	B	C	B	C
Pull-apart and numbered control terminal boards on unit starter—Sizes 1, 2, 3 and 4	No	Yes	Yes	No	Yes	Yes	Yes	Yes	Yes	Yes
Stationary and numbered control terminal boards on unit starter – Sizes 5, 6 and 7	No	Yes	Yes	No	Yes	Yes	Yes	Yes	Yes	Yes
Pull-apart and numbered power terminal boards on unit starter – Sizes 1 and 2. (On Type A wiring: Same type of numbered terminals on starter itself for Sizes 1, 2, 3 and 4)	No	Yes	Yes	No	Yes	Yes	Yes	Yes	Yes	Yes
Numbered terminals on starter itself for power connection with no power terminal boards – Sizes, 5, 6 and 7	Yes	Yes	Yes	Yes	Yes	Yes	Yes	Yes	Yes	Yes
Stationary master terminal boards (Top, bottom or rear of section) For control – Sizes 1 thru 5 / For power – Sizes 1 thru 3	No	No	Yes	No	No	Yes	No	Yes	No	Yes
Unit terminal boards for feeder tap units and distribution panels	No	No	No	No	No	No	No	No	No	No
Starter-unit-mounted pilot devices internally wired to starter – Sizes 1 thru 7	Yes	Yes	Yes	Yes	Yes	Yes	Yes	Yes	Yes	Yes
Terminal board points for remote devices (Excluding extra tie points)	No	Yes	Yes	No	Yes	Yes	Yes	Yes	Yes	Yes
Master terminal-board wiring connections	No	No	Yes	No	No	Yes	No	Yes	No	Yes
Factory-wired interconnections between units in the same motor control center	No	No	No	No	No	No	Yes	Yes	Yes	Yes
Type of Drawings Furnished										
Outline and summary sheet (Schedule of units)	Yes	Yes	Yes	Yes	Yes	Yes	Yes	Yes	Yes	Yes
Unit elementary wiring diagrams showing numbered terminal points (Terminal boards not furnished on Type A)	Yes	Yes	Yes	Yes	Yes	Yes	Yes	Yes	Yes	Yes
Unit elementary wiring diagrams showing numbered terminal points and interconnections to other units and/or to the first level of remote devices	No	No	No	No	No	No	Yes	Yes	Yes	Yes
Schedule of wires to master terminal blocks	No	No	Yes	No	No	Yes	No	Yes	No	Yes
Custom drawings as specified by user	No	No	No	Yes	Yes	Yes	No	No	Yes	Yes

Courtesy of GE Industrial Systems

References:

- I. The Electrical Systems Design & Specification Handbook for Industrial Facilities - By Steven J. Marrano, Craig DiLouie
- II. Switchgear and Control Handbook – By Robert W. Smeaton , McGraw Hill Book Company, New York, USA.
- III. IEEE Recommended Practice for Electrical Power Systems in Commercial Buildings, IEEE Std. 241-1983.
- IV. NEMA Standards Publication ICS 18-2001 (R2007) published by National Electrical Manufacturer Association.
- V. Application Guide for Motor Control Centers by GE Industrial System, Plainville Connecticut, USA.