

Quick installation and start-up guide

ACS580-01 drives

Frame R5

English	7	EN
Deutsch	21	DE
Español	33	ES
Suomi	45	FI
Français	57	FR
Italiano	71	IT
Nederlands	83	NL
Svenska	95	SV

List of related manuals in English

Drive manuals and guides

Code (English)

<i>ACS580-01 user's manual</i>	3AUA0000076333
<i>ACS580-01 quick installation and start-up guide for frames R0 to R3</i>	3AUA0000076332
<i>ACS580-01 quick installation and start-up guide for frame R5</i>	3AXD50000007518
<i>ACS580-01 quick installation and start-up guide for frames R6 to R9</i>	3AXD50000009286
<i>ACS-AP-x assistant control panels user's manual</i>	3AUA0000085685

Option manuals and guides

<i>DPMP-01 mounting platform for ACS-AP control panel</i>	3AUA0000100140
<i>DPMP-02 mounting platform for ACS-AP control panel</i>	3AUA0000136205
<i>FCAN-01 CANopen adapter module user's manual</i>	3AFE68615500
<i>FDNA-01 DeviceNet™ adapter module user's manual</i>	3AFE68573360
<i>FENA-01/-11/-21 Ethernet adapter module user's manual</i>	3AUA0000093568
<i>FLON-01 LonWorks® adapter module user's manual</i>	3AUA0000041017
<i>FPBA-01 PROFIBUS DP adapter module user's manual</i>	3AFE68573271
<i>FSCA-01 RS-485 adapter module user's manual</i>	3AUA0000109533
<i>NETA-21 remote monitoring tool user's manual</i>	3AUA00000969391
<i>NETA-21 remote monitoring tool installation and start-up guide</i>	3AUA0000096881

Tool and maintenance manuals and guides

<i>Drive composer PC tool user's manual</i>	3AUA0000094606
<i>Converter module capacitor reforming instructions</i>	3BFE64059629

You can find manuals and other product documents in PDF format on the Internet. See section [Document library on the Internet](#) on the inside of the back cover. For manuals not available in the Document library, contact your local ABB representative.

The QR code below opens an online listing of the manuals applicable to this product.



[ACS580-01 manuals](#)

3AXD50000007518 Rev A

MUL

EFFECTIVE: 2013-09-02

© 2013 ABB Oy. All Rights Reserved.

A1

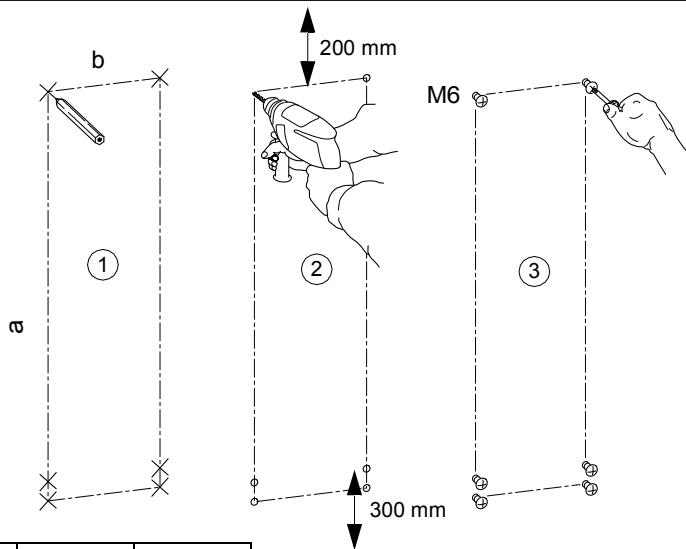

	a (mm)	b (mm)
R5	581/611.5	160

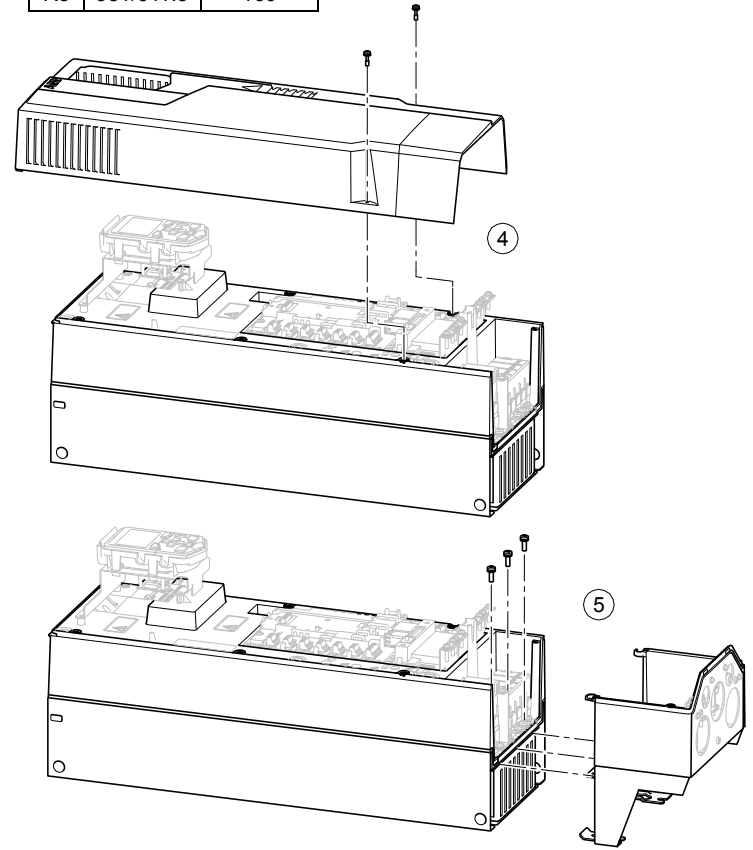

A2

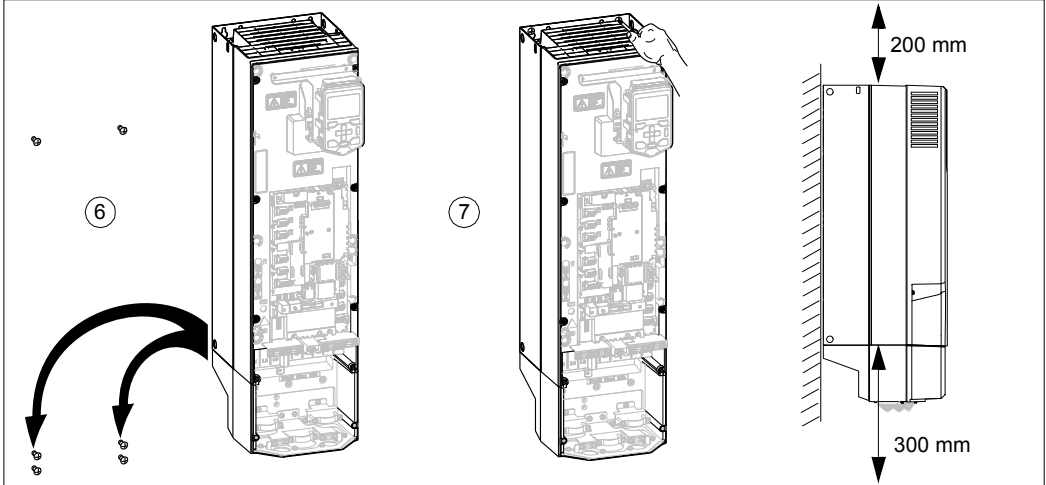

B

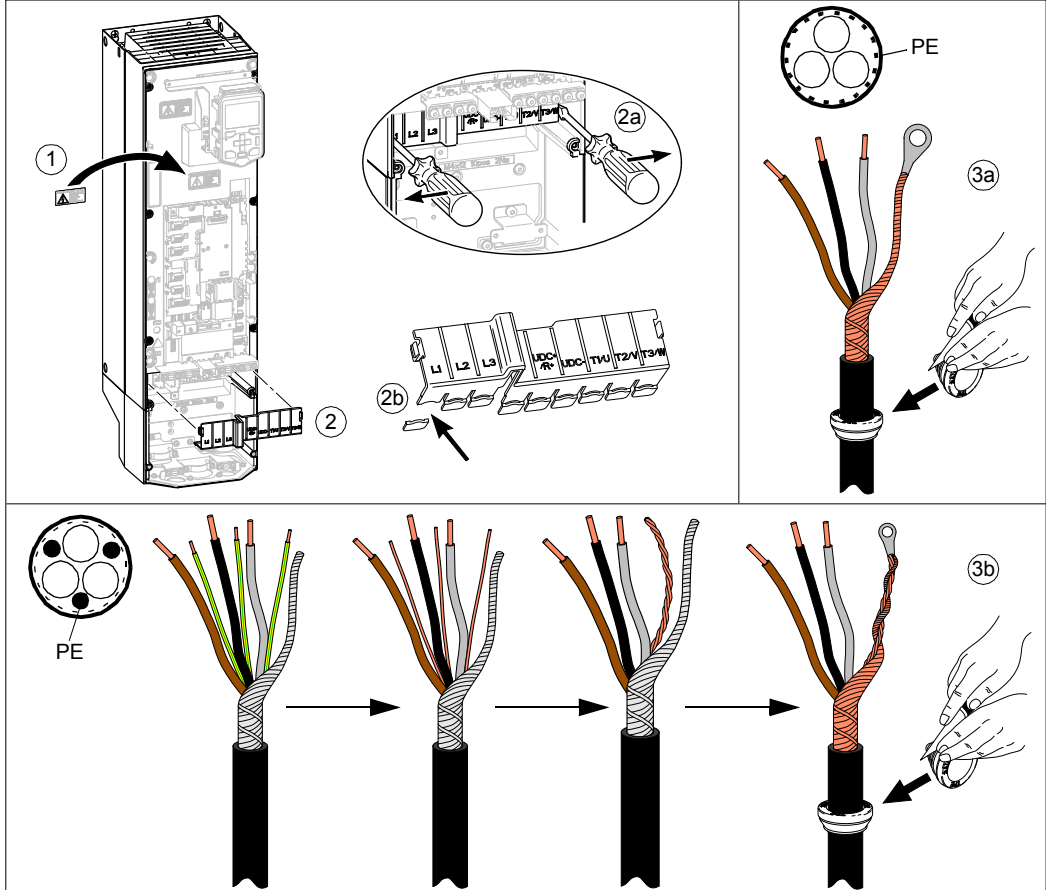

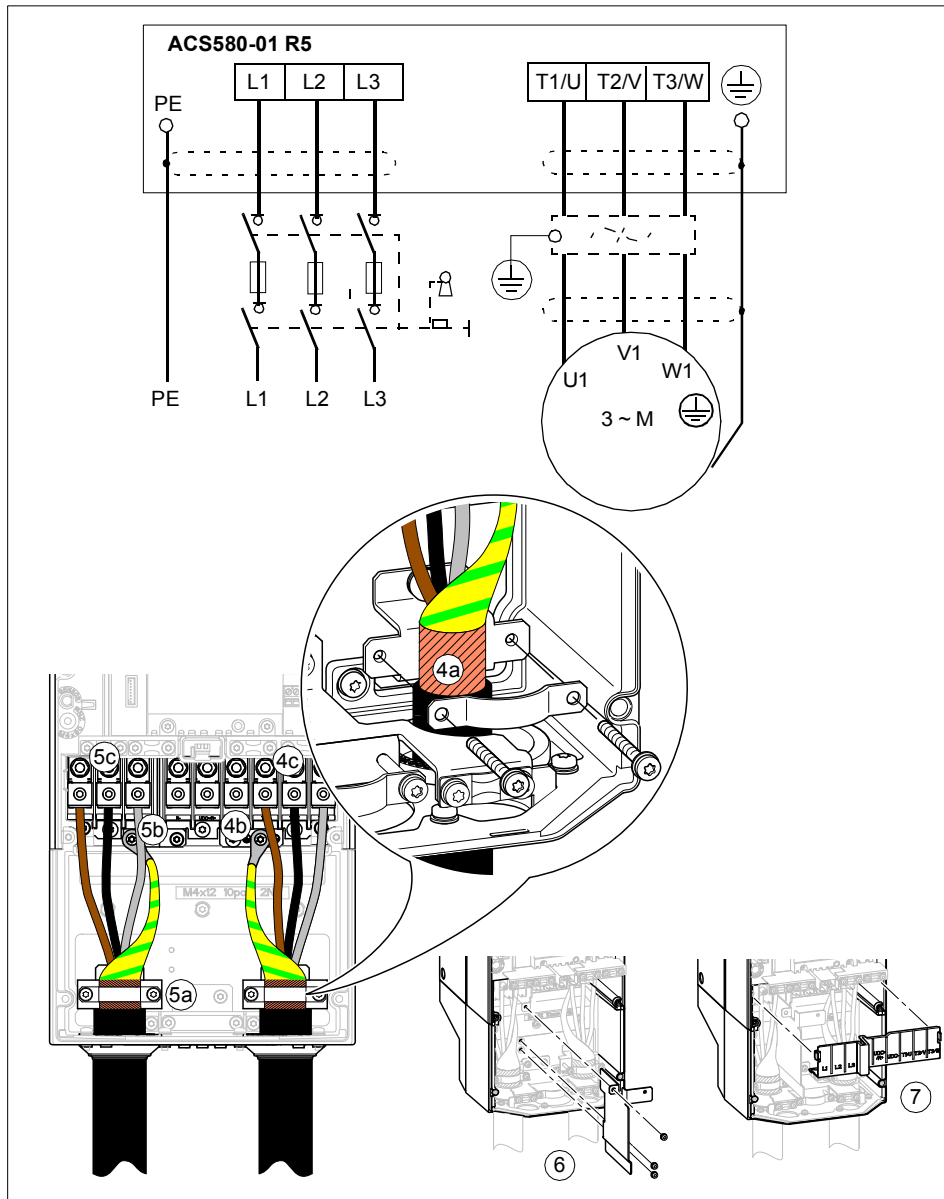

D

	L1, L2, L3, T1/U, T2/V, T3/W	
	(N·m)	(N·m)
R5	15	2.9

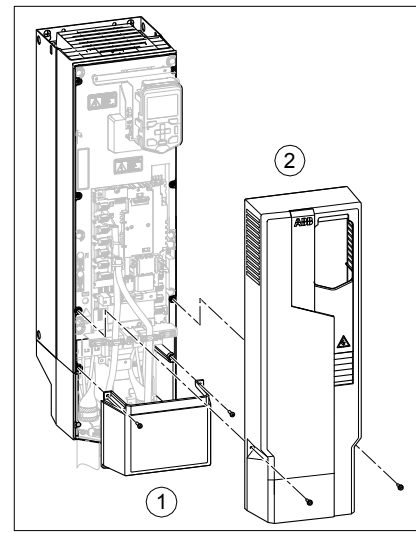
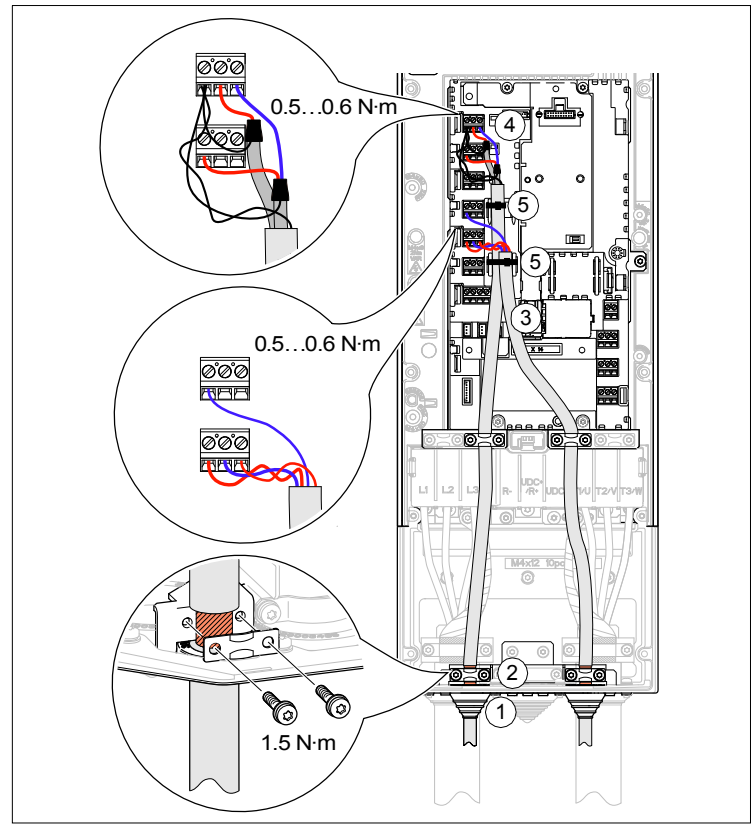
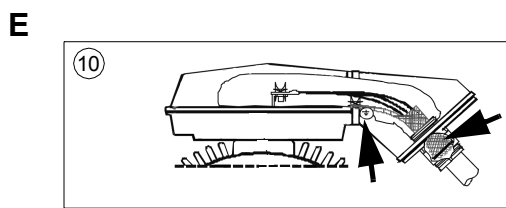

I

ACS580 -01-	Input rating	Output ratings						Maximum losses	Frame size
		Nominal use			Heavy duty use				
	I_{1N}	I_{2N}	P_N	I_{2Ld}	P_{ld}	I_{2Hd}	P_{Hd}	W	
	A	A	kW	A	kW	A	kW	W	
3~ $U_N = 380...415$ V (380, 400, 415 V)									
061A-4	61.0	61.0	30.0	58.0	30.0	44.6	22.0	1153	R5
072A-4	72.0	72.0	37.0	68.4	37.0	61.0	30.0	1153	R5
087A-4	87.0	87.0	45.0	82.7	45.0	72.0	37.0	1156	R5

3AXD00000586715.xls C

II

ACS580 -01-	Input rating	Output ratings				Maximum losses	Frame size
		Nominal use		Heavy duty use			
	I_{1N}	I_{2Ld}	P_{ld}	I_{2Hd}	P_{Hd}	W	
	A	A	hp	A	hp	W	
3~ $U_N = 440...480$ V (440, 460, 480 V)							
061A-4	52.0	52.0	40.0	40.0	30.0	1153	R5
072A-4	65.0	65.0	50.0	52.0	40.0	1153	R5
087A-4	77.0	77.0	60.0	65.0	50.0	1156	R5

3AXD00000586715.xls C

III

ACS580 -01-	gG (IEC 60269)				
	I_N	I^2t	Voltage rating	Manufacturer	Type
	A	A ² s	V		
3~ $U_N = 380...480$ V (380, 400, 415, 440, 460, 480 V)					
061A-4	80	37500	500	ABB	OFAF000H80
072A-4	100	65000	500	ABB	OFAF000H100
087A-4	100	100000	500	ABB	OFAF000H100

3AXD00000586715.xls C

IV

ACS580 -01-	uR or aR				
	I_N	I^2t	Voltage rating	Manufacturer	Type
	A	A ² s	V		
3~ $U_N = 380...480$ V (380, 400, 415, 440, 460, 480 V)					
061A-4	100	4650	690	Cooper Bussmann	170M1567
072A-4	125	8500	690	Cooper Bussmann	170M1568
087A-4	125	8500	690	Cooper Bussmann	170M1568

3AXD00000586715.xls C

V

ACS580 -01-	UL			
	Type	I_N	Voltage rating	Cooper Bussmann type
		A	V	
3~ $U_N = 380...480$ V (380, 400, 415, 440, 460, 480 V)				
061A-4	UL class T	80	600	JJS-80
072A-4	UL class T	90	600	JJS-90
087A-4	UL class T	110	600	JJS-110

3AXD00000586715.xls C

EN – Quick installation and start-up guide

This guide briefly instructs how to install and start-up the drive. For complete information, see *AS580-01 user's manual* (www.abb.com/drives: Select *Document Library* and search for document number 3AUA0000076333 [English]).

Installation

EN

Obey the safety instructions



WARNING! Obey these instructions. If you ignore them, injury or death, or damage to the equipment can occur:

- If you are not a qualified electrician, do not do electrical installation work.
 - Do not work on the drive, motor cable or motor when main power is applied. If the drive is already connected to the input power, wait for 5 minutes after disconnecting the input power.
 - Do not work on the control cables when power is applied to the drive or to the external control circuits.
 - Make sure that debris from borings and grindings does not enter the drive when installing.
 - Make sure that the floor below the drive and the wall where the drive is installed are non-flammable.
-

Check if capacitors need to be reformed

If the drive has been stored for a year or more, you must reform the capacitors.

You can determine the manufacturing time from the serial number, which you find on the type designation label attached to the drive. The serial number is of format MYYWWRXXXX. YY and WW tell the manufacturing year and week as follows:

YY: 13, 14, 15, ... for 2013, 2014, 2015, ...

WW: 01, 02, 03, ... for week 1, week 2, week 3, ...

For information on reforming the capacitors, see *Converter module capacitor reforming instructions* (3BFE64059629 [English]), available on the Internet.

Select the power cables

Size the power cables according to local regulations to carry the nominal current given on the type designation label of your drive.

Ensure the cooling

See tables [I](#) and [II](#) on page [5](#) for the losses. The allowed operating temperature range of the drive without derating is -15 to +40 °C (+5 to +104 °F). No condensation or frost is allowed. For restrictions below 0 °C (+32 °F) and above +40 °C (+104 °F), see chapter *Technical data* in *ACS580-01 user's manual* (3AUA0000076333 [English]).

EN

Protect the drive and input power cable

See tables [III](#), [IV](#) and [V](#) on pages [5](#) and [6](#) for the fuses.

If you are going to use gG fuses, check on the fuse time-current curve to ensure the operating time of the fuse is below 0.5 seconds. Follow the local regulations.

Install the drive on the wall

See figures [A1](#) and [A2](#) on page [3](#).

Note: You can use only two screws instead of four to attach the lower part of the drive.

Check the insulation of the input and motor cables and the motor

Check the insulation of the input cable according to local regulations before connecting it to the drive.

Check the insulation of the motor cable and motor when the cable is disconnected from the drive. Measure the insulation resistance between each phase conductor and the Protective Earth conductor using a measuring voltage of 1000 V DC. The insulation resistance of an ABB motor must exceed 100 Mohm (reference value at 25 °C or 77 °F). For the insulation resistance of other motors, see the manufacturer's instructions.

Note: Moisture inside the motor casing will reduce the insulation resistance. If moisture is suspected, dry the motor and repeat the measurement.

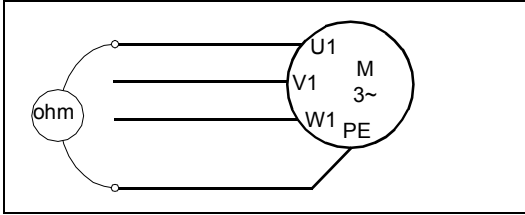

Connect the power cables

EN

See figures [B](#), [C](#), [D](#) and [E](#). Use symmetrical shielded cable for motor cabling. If the cable shield is the sole PE conductor for drive or motor, make sure that it has sufficient conductivity for the PE.

1. Attach the residual voltage warning sticker in the local language next to the control board.
2. Remove the shroud on the power cable terminals by releasing the clips and lifting the shroud up from the sides with a screwdriver (2a). Knock out holes for the cables to be installed (2b).
3. Cut adequate holes into the rubber grommets. Slide the grommets onto the cables. Prepare the ends of the cables as illustrated in the figure. Two different cable types are shown (3a, 3b). **Note:** The bare shield will be grounded 360 degrees. Mark the pigtail made from the shield as a PE conductor with yellow-and-green color. Slide the cables through the holes of the bottom plate and attach the grommets to the holes (the motor cable to the right and the input power cable to the left).
4. Connect the motor cable:
 - Ground the shield 360 degrees under the grounding clamps (4a).
 - Connect the twisted shield of the cable to the grounding terminal (4b).
 - Connect the phase conductors of the cable to the T1/U, T2/V and T3/W terminals. Tighten the screws to the torque given in table [D](#) (4c).
5. Connect the input power cable as in step [4](#). Ground the shield 360 degrees under the grounding clamps (5a). Connect the twisted shield to the grounding terminal

(5b) and the phase conductors to the L1, L2 and L3 terminals. Tighten the screws to the torque given in table [D](#) (5c).

6. Install the EMC shroud separating the input and output cabling.
7. Reinstall the shroud on the power terminals.
8. Put the unused rubber grommets to the holes in the lead-through plate.
9. Secure the cables outside the unit mechanically.
10. Ground the motor cable shield at the motor end. For minimum radio frequency interference, ground the motor cable shield 360 degrees at the lead-through of the motor terminal box.

Connect the control cables

See figure [F](#). It shows a example with one analog signal cable and one digital signal cable. Make the connections according to the macro in use. The default connections of the ABB standard macro are shown in section [Default I/O connections](#) on page [12](#).

1. Cut an adequate hole into the rubber grommet and slide the grommet onto the cable. Slide the cable through a hole of the bottom plate and attach the grommet to the hole.
2. Ground the outer shield of the cable 360 degrees under the grounding clamp. Keep the cable unstripped as close to the terminals of the control board as possible. For analog signal cables, ground also the pair-cable shields and grounding wire at the SCR1 terminal. Secure the cables mechanically at the clamps below the control unit.
3. Route the cable as shown in the figure.
4. Connect the conductors to the appropriate terminals of the control board and tighten to 0.5...0.6 N·m.
5. Tie all control cables to the provided cable tie mounts.

Default I/O connections

Default I/O connections of the ABB Standard macro are shown below.

ABB standard macro:

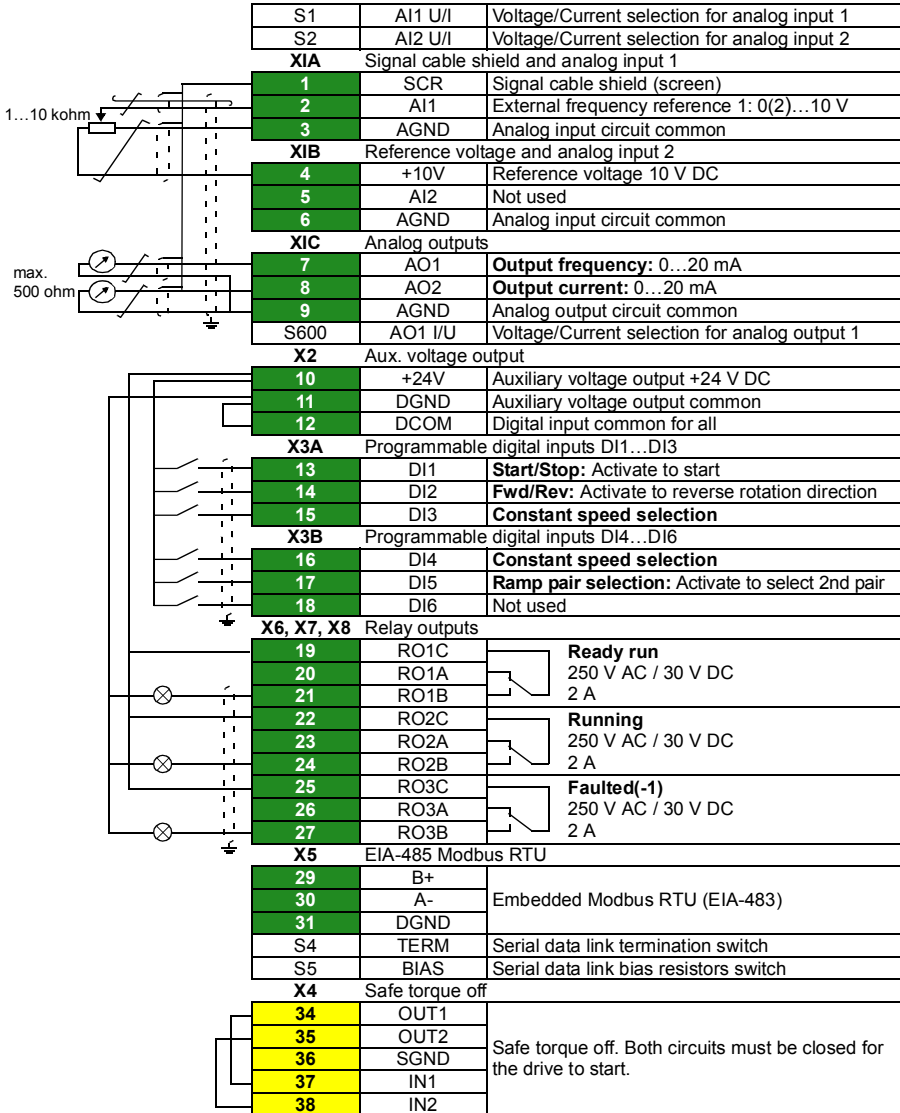

Total load capacity of the Auxiliary voltage output +24V (X2:10) is 6.0 W (250 mA / 24 V) .
Wire sizes: 0.14...2.5 mm² (terminals +24V, DGND, DCOM, DI, AI, AOO, AGND, RO, STO)
Tightening torques: 0.5...0.6 N·m

Install optional modules, if any

See chapter *Electrical installation* in *ACS580-01 user's manual* (3AUA0000076333 [English]).

Check the compatibility with IT (ungrounded) and corner-grounded TN systems

EN



WARNING! Do not install the drive with the internal EMC filter connected on an IT system (an ungrounded power system or a high-resistance-grounded [over 30 ohms] power system) or on a corner-grounded TN system.

If you connect the drive to an IT (ungrounded) or a corner-grounded TN system, disconnect the EMC filters before connecting the drive to the supply network. For information on how to do it, see chapter *Electrical installation* in *ACS580-01 user's manual* (3AUA0000076333 [English]).

Reinstall covers

See figure [G](#).

1. Install the cover of the cable entry box.
 2. Tighten the two retaining screws with a screwdriver.
 3. Reinstall the module cover. Put the tabs on the cover top in their counterparts on the housing and then press the cover.
 4. Tighten the two retaining screws with a screwdriver.
-

Start-up











This chapter describes the start-up of the drive using the First start assistant on the assistant control panel.

Complete documentation of the drive firmware: program features, parameters and fault tracing can be found in *AS580-01 user's manual* (3AUA0000076333 [English]). For more information on the assistant panels, see *ACS-AP-x assistant control panels user's manual* (3AUA0000085685 [English]).











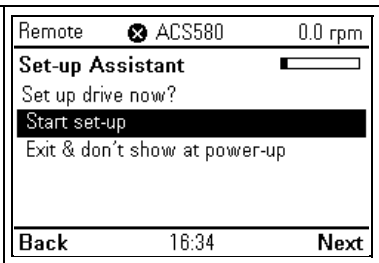

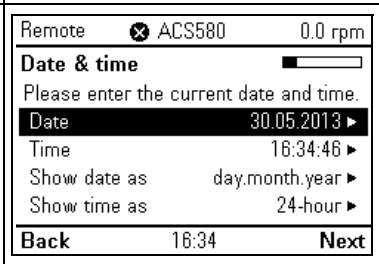

EN Before you start

Ensure that the drive has been installed as described in section [Installation](#) on page 7.

Start-up with the First start assistant on an assistant panel

Safety	
	Obey the safety instructions on page 7 during the start-up procedure.
<input type="checkbox"/>	Check the installation.
<input type="checkbox"/>	Check that the starting of the motor does not cause any danger. De-couple the driven machine if there is a risk of damage in case of an incorrect direction of rotation.
Hints on using the assistant control panel	
<p>The two commands at the bottom of the display (in the figure on the right, Options and Menu), show the functions of the two softkeys  and  located below the display. The commands assigned to the softkeys vary depending on the context.</p> <p>Use keys , ,  and  to move the cursor and/or change values depending on the active view.</p> <p>Key  shows a context-sensitive help page.</p>	
1 – First start assistant guided settings: Language, date and time, and motor nominal values	
<input type="checkbox"/>	Have the motor name plate data at hand. Power up the drive.
<input type="checkbox"/>	<p>The First start assistant guides you through the first start-up. The start-up begins automatically. Wait until the control panel enters the view shown on the right. Select the language you want to use by highlighting it and pressing  (OK).</p> <div style="border: 1px solid black; padding: 5px; margin-top: 10px;"> <p>English</p> <p>Deutsch</p> <p>Suomi</p> <p>Français</p> <p>Italiano</p> <p>Nederlands</p> <p>Svenska</p> <p style="text-align: right;">OK ►</p> </div>

EN

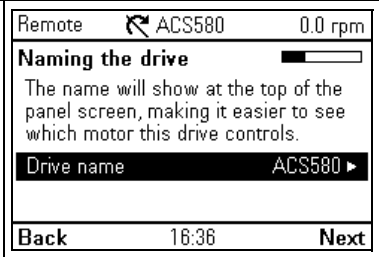
<p><input type="checkbox"/> Highlight Start set-up (if not already highlighted) and press  (Next).</p>	
<p><input type="checkbox"/> Set the date, time, as well as date and time display formats.</p> <ul style="list-style-type: none"> • Go to the edit view of a highlighted row by pressing . • Scroll the view with  and . <p>Go to the next view by pressing  (Next).</p>	
<p><input type="checkbox"/> In an edit view:</p> <ul style="list-style-type: none"> • Use  and  to move the cursor left and right. • Use  and  to change the value. • Press  (Save) to accept the new setting, or press  (Cancel) to go back to the previous view without making changes. 	
<p><input type="checkbox"/> To give the drive a name that will be shown at the top, press .</p> <p>If you do not want to change the default name (ACS580), continue straight to the set-up of the motor nominal values by pressing  (Next).</p> <p>For information on editing text, see <i>ACS580-01 user's manual</i> (3AUA0000076333 [English]) or <i>ACS-AP-x assistant control panels user's manual</i> (3AUA0000085685 [English]).</p>	

Refer to the motor nameplate for the following nominal value settings of the motor. Whenever possible, enter the values exactly as shown on the motor nameplate.

Example of a nameplate of an induction (asynchronous) motor:

ABB Motors									
3 ~ motor		M2AA 200 MLA 4							
		IEC 200 M/L 55							
		No		Ins.cl. F		IP 55			
V	Hz	kW	r/min	A	cos φ	IA/IN	tE/s		
690 Y	50	30	1475	32.5	0.83				
400 D	50	30	1475	56	0.83				
660 Y	50	30	1470	34	0.83				
380 D	50	30	1470	59	0.83				
415 D	50	30	1475	54	0.83				
440 D	60	35	1770	59	0.83				
Cat. no		3GAA 202 001 - ADA							
6312/C3		6210/C3		180 kg					
IEC 34-1									

- Check that the motor data is correct. Values are predefined on the basis of the drive size but you should verify that they correspond to the motor. Start with the motor nominal current. Motor nominal cosφ and nominal torque are optional. Press (**Next**) to continue.

Remote ACS580 0.0 rpm

Motor nominal values ▬

Find the values on the motor's nameplate, and enter them here:

Motor nominal current 1.8 A ▶

Motor nominal voltage 400.0 V ▶

Motor nominal frequency 50.00 Hz ▶

Back 16:42 **Next**

- To do the direction test, highlight **Spin the motor** and press (**Next**).

Remote ACS580 45.9 Hz

Direction test? ▬

Spin the motor to check direction?

Not now

Spin the motor ▶

Back 16:49 **Next**

- First switch to local control by pressing the Loc/Rem key. Local control is indicated by the text "Local" on the top pane. Then press the Start key on the panel to start the drive.







Local ACS580 45.9 Hz

Press Start ▬



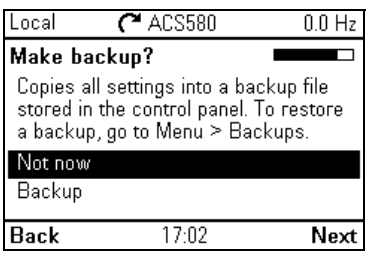

Warning: Until set-up is done, safeties are not active and motor speed is 5 Hz.

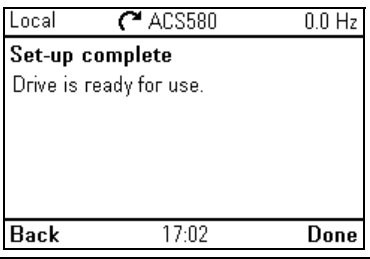
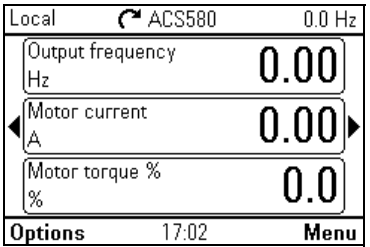
Press Start now to spin the motor, then check the direction of rotation.

Back 16:51

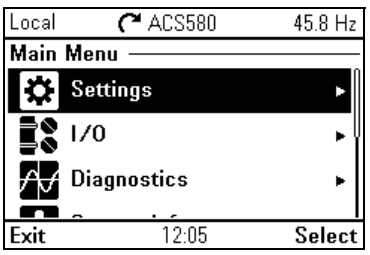
<input type="checkbox"/> Check the direction of the motor. If it is forward, highlight (if not already highlighted) Yes, motor is spinning forward and press  (Next) to continue. If the direction is not forward, highlight No, fix direction and press  (Next) to continue.	 <p>Local ACS580 5.0 Hz</p> <p>Is this forward?</p> <p>Selecting "No, fix direction" tells the drive to change direction, and labels the new direction "forward".</p> <p>Yes, motor is spinning forward</p> <p>No, fix direction</p> <p>Back 17:01 Next</p>
<input type="checkbox"/> If you want to make a backup of the settings made so far, select Backup and press  (Next). If you do not want to make a backup, select Not now and press  (Next).	 <p>Local ACS580 0.0 Hz</p> <p>Make backup?</p> <p>Copies all settings into a backup file stored in the control panel. To restore a backup, go to Menu > Backups.</p> <p>Not now</p> <p>Backup</p> <p>Back 17:02 Next</p>
<input type="checkbox"/> The set-up is now complete and the drive is ready for use. Press  (Done) to enter the Home view.	 <p>Local ACS580 0.0 Hz</p> <p>Set-up complete</p> <p>Drive is ready for use.</p> <p>Back 17:02 Done</p>
<input type="checkbox"/> The Home view monitoring the values of the selected signals is shown on the panel.	 <p>Local ACS580 0.0 Hz</p> <p>Output frequency 0.00 Hz</p> <p>Motor current 0.00 A</p> <p>Motor torque % 0.0 %</p> <p>Options 17:02 Menu</p>

2 – Additional settings: for example macro, ramps, limits

<input type="checkbox"/> Make any additional settings, for example macro, ramps, and limits starting from the Main menu - press  (Menu) to enter the Main menu . For more information, see the start-up procedure in <i>ACS580-01 user's manual</i> (3AUA0000076333 [English]).	 <p>Local ACS580 45.8 Hz</p> <p>Main Menu</p> <ul style="list-style-type: none">  Settings ▶  I/O ▶  Diagnostics ▶ <p>Exit 12:05 Select</p>
--	--



DE – Kurzanleitung für die Installation und Inbetriebnahme

Diese Kurzanleitung enthält die notwendigen Informationen für die Installation und Inbetriebnahme des Frequenzumrichters. Die komplette Dokumentation enthält das Handbuch *AS580-01 user's manual* (www.abb.com/drives: Wählen Sie *Document Library* und suchen Sie das Dokument mit der Nummer 3AUA0000076333 [Englisch]).

Installation

Befolgen Sie die Sicherheitsvorschriften.



WARNUNG! Befolgen Sie diese Vorschriften. Wenn diese nicht befolgt werden, können Verletzungen, tödliche Unfälle oder Schäden an den Geräten auftreten:

- Elektrische Installationsarbeiten dürfen nur von Fachpersonal durchgeführt werden.
 - Am Frequenzumrichter, dem Motorkabel oder dem Motor dürfen keinerlei Arbeiten ausgeführt werden, solange die Netzspannung anliegt. Ist der Frequenzumrichter bereits an die Spannungsversorgung angeschlossen, warten Sie fünf Minuten nach dem Trennen von der Spannungsversorgung.
 - Führen Sie keine Arbeiten an den Steuerkabeln durch, wenn Spannung am Frequenzumrichter oder an externen Steuerkreisen anliegt.
 - Stellen Sie sicher, dass bei der Installation keine Bohrspäne und Staub in den Frequenzumrichter eindringen.
 - Stellen Sie sicher, dass der Boden unterhalb des Frequenzumrichters und die Wand, an der der Frequenzumrichter montiert wird aus nicht brennbarem Material bestehen.
-

Prüfen Sie, ob Kondensatoren nachformiert werden müssen

Wenn der Frequenzumrichter ein Jahr oder länger gelagert wurde, müssen die Kondensatoren nachformiert werden.

Das Herstellungsdatum kann anhand der Seriennummer bestimmt werden, welche auf dem Typenschild (seitlich am Frequenzumrichter angebracht) angegeben ist.

Die Seriennummer hat das Format MJJWWRXXXX.
JJ und WW geben das Herstellungsjahr und die -woche an:

JJ: 13, 14, 15, ... für 2013, 2014, 2015, ...
WW: 01, 02, 03, ... für Woche 1, Woche 2, Woche 3, ...

Informationen zum Formieren der Kondensatoren siehe die Anleitung *Converter module capacitor reforming instructions* (3BFE64059629 [Englisch]), die im Internet verfügbar ist.

Auswahl der Leistungskabel

Die Leistungskabel müssen nach den örtlichen Vorschriften für den auf dem Typenschild des Frequenzumrichters angegebenen Nennstrom ausreichend bemessen sein.

DE

Ausreichende Kühlung sicherstellen

Siehe Tabellen *I* und *II* auf Seite *5* mit den Verlustleistungen. Der zulässige Umgebungstemperaturbereich für den Betrieb des Frequenzumrichters ohne Leistungsminderung ist -15 bis +40 °C (+5 bis 104 °F). Kondensation und/oder Eisbildung sind nicht zulässig. Einschränkungen für den Betrieb unter 0 °C (+32 °F) und über +40 °C (+104 °F) siehe Kapitel *Technical data* im Handbuch *ACS580-01 user's manual* (3AUA0000076333 [Englisch]).

Schutz des Frequenzumrichters und der Einspeisekabel

Anaben zu den Sicherungen enthält die Tabellen *III*, *IV* und *V* auf Seiten *5* und *6*.

Wenn Sie Sicherungen des Typs gG benutzen, prüfen Sie anhand der Zeit-Stromkurve der Sicherung, ob die Ansprechzeit unter 0,5 Sekunden liegt. Befolgen Sie die örtlichen Vorschriften.

Wandmontage des Frequenzumrichters

Siehe Abbildungen *A1* und *A2* auf Seite *3*.

Hinweis: Für die Befestigung des unteren Teils des Frequenzumrichters können Sie nur zwei anstatt vier Schrauben benutzen.

Prüfung der Isolation der Einspeise- und Motorkabel und des Motors

Prüfen Sie die Isolation des Einspeisekabels nach den örtlichen Vorschriften bevor dieses an den Frequenzumrichter angeschlossen wird.

Prüfen Sie die Isolation des Motorkabels und des Motors, wenn das Motorkabel vom Frequenzumrichter getrennt ist. Messen Sie die Isolationswiderstände zwischen jeder Phase und der Schutzterde mit einer Messspannung von 1000 V DC.

Der Isolationswiderstand eines ABB-Motors muss mehr als 100 MOhm betragen (Referenzwert bei 25 °C bzw. 77 °F). Die Isolationswiderstände anderer Motoren entnehmen Sie bitte der jeweiligen Anleitung des Herstellers.

Hinweis: Feuchtigkeit innerhalb des Motorgehäuses reduziert den Isolationswiderstand. Bei Verdacht auf Feuchtigkeit den Motor trocknen und die Messung wiederholen.

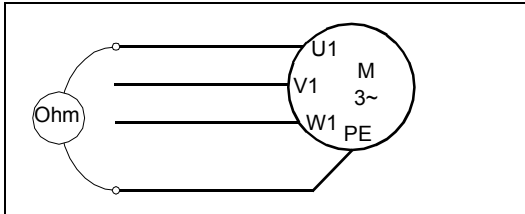

Anschließen der Leistungskabel

Siehe Abbildungen *B*, *C*, *D* und *E*. Ein symmetrisch geschirmtes Motorkabel verwenden. Wenn der Kabelschirm der einzige PE-Leiter für den Frequenzumrichter oder Motor ist, stellen Sie sicher, dass er eine ausreichend bemessene Leitfähigkeit für den PE hat.

1. Den Restspannungs-Warnaufkleber in der erforderlichen lokalen Sprache neben der Regelungseinheit anbringen.
2. Die Abdeckung von den Leistungskabelklemmen entfernen. Hierzu die Clips lösen und die Abdeckung an den Seiten mit einem Schraubendreher (2a) loshebeln. Die Öffnungen für die zu installierenden Kabel ausbrechen (2b).
3. Passende Öffnungen in die Gummidichtungen schneiden. Dichtungen auf die Kabel schieben. Die Enden der Kabel, wie in der Abbildung gezeigt, vorbereiten. Es werden zwei verschiedene Kabeltypen gezeigt (3a, 3b).

Hinweis: Der blanke Schirm des Kabels wird 360 Grad geerdet. Kennzeichnen Sie das verdrehte Schirmbündel als PE-Leiter mit einer gelb-grünen Markierung. Stecken Sie die Kabel durch die Bohrungen in der Bodenplatte und setzen Sie die Gummidichtungen in die Bohrungen (das Motorkabel rechts und das Einspeisekabel links).

4. Anschließen des Motorkabels:
 - Die blanken Kabelschirme 360 Grad unter den Kabelerdungsschellen erden (4a).
 - Den verdrehten Schirm des Kabels an die PE-Klemme anschließen (4b).
 - Die Phasenleiter des Kabels an die Klemmen T1/U, T2/V und T3/W anschließen. Die Schrauben mit dem in Tabelle *D* (4c) angegebenen Anzugsmoment festziehen.

5. Das Einspeisekabel, wie in Schritt 4 beschrieben, anschließen. Die blanken Kabelschirme 360 Grad unter den Kabelschellen (5a) erden. Schließen Sie den verdrehten Kabelschirm an die Erdungsklemme (5b) und die Phasenleiter an die Klemmen L1, L2 und L3 an. Die Schrauben mit dem in Tabelle D (5c) angegebenen Anzugsmoment festziehen.
6. Das EMV-Abdeckblech wieder montieren, mit dem die Eingangs- von der Ausgangsverkabelung getrennt wird.
7. Die Abdeckung wieder auf den Leistungskabelklemmen anbringen.
8. Die unbenutzten Gummidichtungen in die Öffnungen der Durchführungsplatte stecken.
9. Die Kabel außerhalb der Einheit mechanisch sichern.
10. Die Motorkabelschirme motorseitig an Erde/PE anschließen. Für minimale HF-Störungen muss der Kabelschirm an der Eingangsverschraubung des Motorklemmenkastens mit einer 360-Grad-Erdung versehen werden,

DE

Anschließen der Steuerkabel

Siehe Abbildung F. Es wird ein Beispiel mit einem Analogsignalkabel und einem Digitalsignalkabel gezeigt. Nehmen Sie die Anschlüsse entsprechend des benutzten Makros vor. Die Standardanschlüsse des Makros ABB Standard sind in Abschnitt [Standard E/A-Anschlüsse](#) auf Seite 25 dargestellt.

1. Eine passende Öffnung in die Gummidurchführungsdichtung schneiden und die Dichtung auf das Kabel schieben. Das Kabel durch die Öffnung des unteren Abschlussblechs stecken und die Dichtung in die Öffnung drücken.
2. Den blanken Schirm des Kabels 360 Grad unter der Erdungsklemme verschrauben und erden. Das Kabel mit durchgängigem Schirm so nahe wie möglich an die Klemmen der Regelungseinheit führen. Für Analogsignalkabel auch die beiden Schirme der paarweisen Einzelleiter und den Erdungsleiter an Klemme SCR1 anschließen (erden). Die Kabel an den Schellen unter der Regelungseinheit mechanisch sichern.
3. Die Kabel so, wie in der Abbildung gezeigt, verlegen.
4. Die Leiter an die entsprechenden Klemmen der Regelungseinheit anschließen und mit 0,5...0,6 Nm festziehen.
5. Alle Steuerkabel an den vorgesehenen Kabelhalterungen befestigen.

Standard E/A-Anschlüsse

Im folgenden Anschlussplan sind die Standard-E/A-Anschlüsse des Makros ABB Standard dargestellt.

Anschlussplan der Standard-E/A-Anschlüsse

ABB Standard-Makro

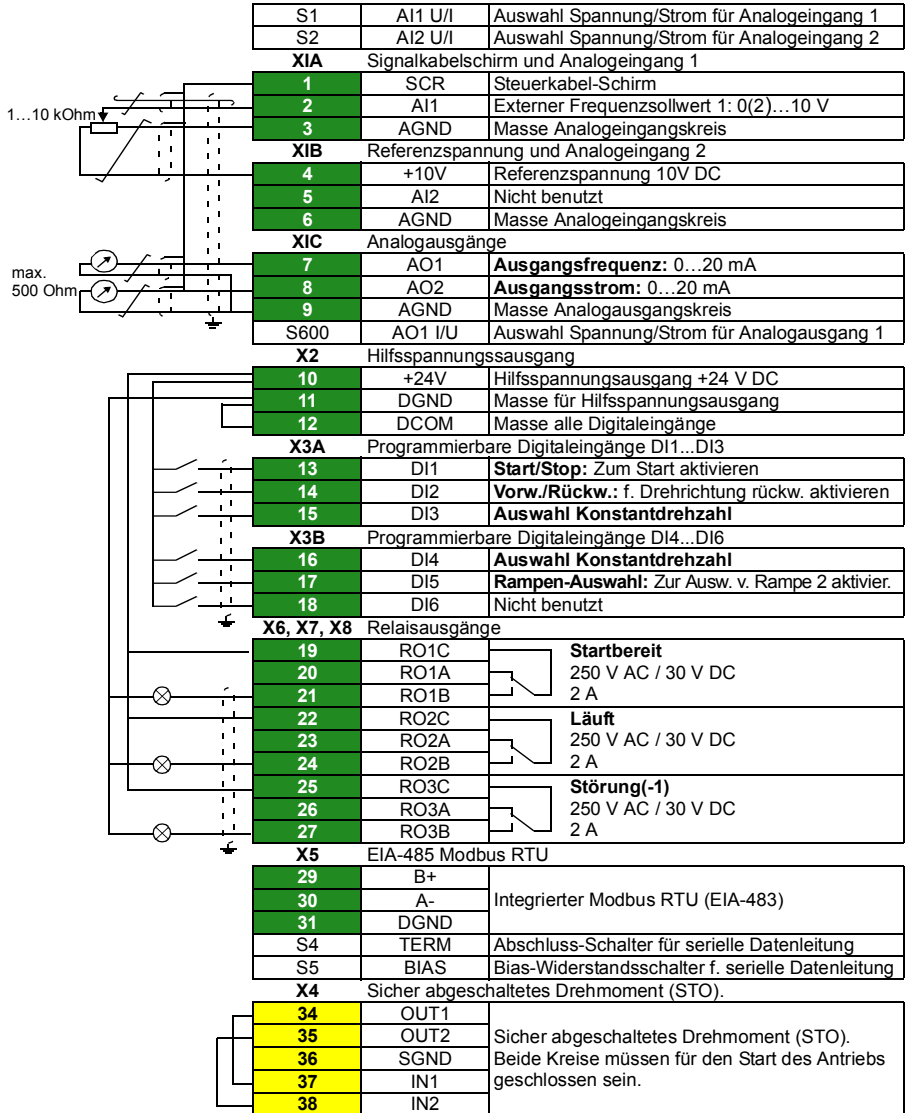

Die Gesamtlastkapazität des Hilfsspannungsausgangs +24V (X2:10) ist 6.0 W (250 mA/24 V).
 Leitergrößen: 0,14...2,5 mm²(Klemmen +24V, DGND, DCOM, DI, AI, AOO, AGND, RO, STO)
 Anzugsmomente: 0,5...0,6 Nm

DE

Installation optionaler Module, falls vorhanden

Siehe Kapitel *Electrical installation* im Handbuch *ACS580-01 user's manual* (3AUA0000076333 [Englisch]).

Prüfung der Kompatibilität mit IT- (ungeerdeten) und asymmetrisch geerdeten TN-Netzen



WARNUNG! Der Frequenzumrichter darf mit dem internen EMV-Filter nicht an ein IT-Netz (an ein ungeerdetes oder ein hochohmig geerdetes [über 30 Ohm] Netz) oder ein asymmetrisch geerdetes TN-Netz angeschlossen werden.

DE

Wenn der Frequenzumrichter an ein IT (ungeerdetes) oder ein asymmetrisch geerdetes TN-Netz angeschlossen werden soll, müssen integrierte EMV-Filter vor dem Anschluss an das Einspeisernetz entfernt werden. Informationen darüber enthält Kapitel *Electrical installation* im Handbuch *ACS580-01 user's manual* (3AUA0000076333 [Englisch]).

Abdeckungen wieder installieren

Siehe Abbildung [G](#).

1. Die Abdeckungen des Kabelanschlusskastens wieder installieren.
2. Die zwei Halteschrauben mit einem Schraubendreher festziehen.
3. Die Modulabdeckung wieder installieren. Die Halterungen oben an der Abdeckung in ihre Führung am Gehäuse setzen und dann die Abdeckung mit Druck aufsetzen.
4. Die zwei Halteschrauben mit einem Schraubendreher festziehen.

Inbetriebnahme











Dieses Kapitel beschreibt die Erst-Inbetriebnahme des Frequenzumrichters mit dem Inbetriebnahme-Assistenten des Komfort-Bedienpanels.

Die komplette Dokumentation der Frequenzumrichter-Firmware: Programm-Merkmale, Parameter und Störungsanzeigen enthält das Handbuch *AS580-01 user's manual* (3AUA0000076333 [Englisch]). Weitere Informationen zum Bedienpanel enthält das Handbuch *ACS-AP-x Assistant control panels user's manual* (3AUA0000085685 [Englisch]).











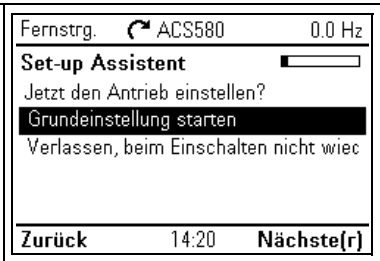





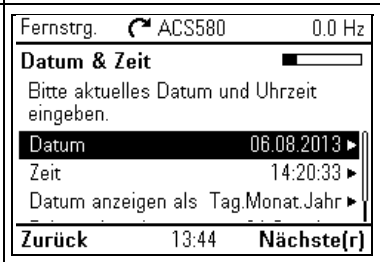









Vor Beginn der Arbeit

Stellen Sie sicher, dass der Frequenzumrichter entsprechend der Beschreibung in Abschnitt [Installation](#) auf Seite 21 installiert wurde.

Inbetriebnahme mit dem Assistenten/Bedienpanel

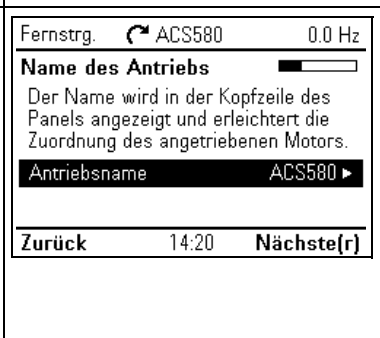
Sicherheit	
	Befolgen Sie bei der Inbetriebnahme die Sicherheitsvorschriften auf Seite 21.
<input type="checkbox"/>	Prüfen Sie die Installation.
<input type="checkbox"/>	Prüfen Sie, dass durch den Start des Motors keine Gefährdungen entstehen. Koppeln Sie die angetriebene Maschine ab , wenn durch eine falsche Drehrichtung eine Gefährdung entsteht.
Hinweise zur Verwendung des Komfort-Bedienpanels	
<p>Die zwei Befehlsanzeigen am unteren Rand des Displays (im Bild rechts Options/Optionen und Menu/Menü) zeigen die Funktionen der zwei Funktionstasten  und  an, die sich unter dem Display befinden. Die den Funktionstasten zugeordneten Befehlsanzeigen sind vom Kontext / Betriebszustand abhängig.</p> <p>Mit den Tasten , ,  und  können Sie, je nach aktiver Ansicht, den Cursor bewegen und/oder Werte ändern.</p> <p>Taste  zeigt eine kontextsensitive Hilfe-Seite an.</p>	
1 – Erste Inbetriebnahme mit dem Assistenten Grundeinstellungen: Sprache, Datum und Zeit, Motor-Nenndaten	
<input type="checkbox"/>	Zur Einstellung müssen die Daten vom Motortypenschild verfügbar sein. Den Frequenzumrichter einschalten.
<input type="checkbox"/>	Der Assistent führt Sie durch die Grundeinstellungen für die erste Inbetriebnahme. Die Inbetriebnahme beginnt automatisch. Warten bis das Bedienpanel die erste Ansicht, wie rechts dargestellt, anzeigt. Auswahl der Sprache, die benutzt werden soll: Die markierte Sprache mit  (OK) übernehmen.
	

DE

<p><input type="checkbox"/> Markieren Sie Start set-up/Grundeinstellung starten (wenn nicht bereits ausgewählt) und Taste  (Next/Nächste) drücken.</p>	 <p>Fernstrg.  ACS580 0.0 Hz</p> <p>Set-up Assistent </p> <p>Jetzt den Antrieb einstellen?</p> <p>Grundeinstellung starten</p> <p>Verlassen, beim Einschalten nicht wies</p> <hr/> <p>Zurück 14:20 Nächste(r)</p>
<p><input type="checkbox"/> Datum und Uhrzeit sowie das Anzeigeformat von Datum und Uhrzeit einstellen.</p> <ul style="list-style-type: none"> Die Einstellung für die markierte Zeile können Sie mit Taste  (Edit / Bearbeiten) aufrufen. Blättern durch die Ansicht mit den Tasten  und . <p>In die nächste Ansicht gelangen Sie mit Taste  (Next/Nächste).</p>	 <p>Fernstrg.  ACS580 0.0 Hz</p> <p>Datum & Zeit </p> <p>Bitte aktuelles Datum und Uhrzeit eingeben.</p> <p>Datum 06.08.2013 </p> <p>Zeit 14:20:33 </p> <p>Datum anzeigen als Tag.Monat.Jahr </p> <hr/> <p>Zurück 13:44 Nächste(r)</p>
<p><input type="checkbox"/> In der Ansicht EDIT (Bearbeiten) können Sie:</p> <ul style="list-style-type: none"> Mit den Tasten  und  den Cursor nach links und rechts bewegen. Mit den Tasten  und  den Einstellwert ändern. Mit Taste  (Save/Speichern) die neue Einstellung übernehmen, oder mit Taste  (Cancel/Abbrechen) ohne Änderungen zur vorhergehenden Ansicht zurückkehren. 	 <p>Fernstrg.  ACS580 0.0 Hz</p> <p>Datum</p> <p>Tag Monat Jahr</p> <p>06.08.2013</p> <p>Dienstag</p> <hr/> <p>Abbrechen 14:20 Speichern</p>
<p><input type="checkbox"/> Um dem Frequenzrichter einen Namen zu geben, der in der Kopfzeile angezeigt wird, drücken Sie Taste .</p> <p>Wenn der Standardname (ACS580) nicht geändert werden soll, können Sie direkt mit der Eingabe der Motor-Nennwerte mit Taste  (Next/Nächste) fortfahren.</p> <p>Informationen zum Bearbeiten von Text enthalten die Handbücher <i>ACS580-01 user's manual</i> (3AUA0000076333 [Englisch]) oder <i>ACS-AP-x assistant control panels user's manual</i> (3AUA0000085685 [Englisch]).</p>	 <p>Fernstrg.  ACS580 0.0 Hz</p> <p>Name des Antriebs </p> <p>Der Name wird in der Kopfzeile des Panels angezeigt und erleichtert die Zuordnung des angetriebenen Motors.</p> <p>Antriebsname ACS580 </p> <hr/> <p>Zurück 14:20 Nächste(r)</p>

Für die folgenden Einstellungen die Nenndaten vom Motor-Typenschild verwenden. Wenn möglich, die auf dem Motor-Typenschild eingetragenen Werte genau eingeben.

Beispiel für ein Typenschild eines Asynchronmotors:

ABB Motors									
3 ~ motor		M2AA 200 MLA 4							
		IEC 200 M/L 55							
		No		Ins.cl. F		IP 55			
V	Hz	kW	r/min	A	cos φ	IA/IN	tE/s		
690 Y	50	30	1475	32.5	0.83				
400 D	50	30	1475	56	0.83				
660 Y	50	30	1470	34	0.83				
380 D	50	30	1470	59	0.83				
415 D	50	30	1475	54	0.83				
440 D	60	35	1770	59	0.83				
Cat. no		3GAA 202 001 - ADA							
6312/C3		6210/C3		180 kg					
IEC 34-1									

Prüfen Sie, ob die Motordaten korrekt eingegeben wurden. Die Werte sind auf Basis der Frequenzrichtergröße voreingestellt und Sie müssen sicherstellen, dass sie mit den Daten auf dem Motor-Typenschild übereinstimmen. Beginnen Sie mit dem Motornennstrom. Motornenn-cosφ und Motornennmoment sind optional. Mit Taste (Next/Nächste) fortfahren.

Fernstrg. ACS580 0.0 Hz

Motorenndaten

Auf dem Motortypenschild angegebene Werte hier eingeben:

Motor-Nennstrom 1.8 A

Motor-Nennspannung 400.0 V

Motor-Nennfrequenz 50.00 Hz

Zurück 14:21 Nächste(r)

Für einen Drehrichtungstest die Zeile **Spin the motor/Den Motor drehen** markieren und Taste (Next/Nächste) drücken.

Fernstrg. ACS580 0.0 Hz

Drehrichtungstest?

Motor zum Prüfen der Drehrichtung drehen?

Nicht jetzt

Den Motor drehen

Zurück 14:22 Nächste(r)

Zuerst durch Drücken der Taste auf Lokalsteuerung schalten. Die Lokalsteuerung wird durch "Local/Lokal" oben im Display angezeigt. Dann die Taste Start auf dem Panel drücken, um den Antrieb zu starten.











Lokal ACS580 0.0 Hz

Start-Taste drücken

Warnung: Bis zum Abschluss der Einstellungen sind keine Sicherungen aktiv und der Motor dreht mit 5 Hz.

Zum Drehen des Motors Start drücken und dann die Drehrichtung

Zurück 14:22

<p><input type="checkbox"/> Prüfen Sie die Drehrichtung des Motors. Bei Drehrichtung vorwärts markieren Sie (falls noch nicht markiert) Yes, motor is spinning forward/Ja, Motor dreht vorwärts und gehen Sie mit Taste  (Next/Nächste) weiter. Ist die Drehrichtung nicht vorwärts, markieren Sie No, fix direction/Nein, Drehrichtung ändern und gehen Sie mit Taste  (Next/Nächste) weiter.</p>	<p>Lokal  ACS580 5.0 Hz</p> <p>Ist das vorwärts? </p> <p>Mit Ausw. "Nein, Drehrichtung ändern" wechselt d. Antrieb die Drehrichtung u. interpretiert die Richtung als "vorwärts".</p> <p>Ja, Motor dreht vorwärts</p> <p>Nein, Drehrichtung ändern</p> <p>Zurück 14:22 Nächste(r)</p>
<p><input type="checkbox"/> Wenn Sie für die bis hier vorgenommenen Einstellungen ein Backup erstellen möchten, wählen Sie Backup und dann drücken Sie Taste  (Next/Nächste). Wenn Sie kein Backup erstellen wollen, wählen Sie Not now/Nicht jetzt und dann drücken Sie Taste  (Next/Nächste).</p>	<p>Lokal  ACS580 0.0 Hz</p> <p>Backup erstellen? </p> <p>Kopiert alle Einstellungen als Backup-Datei in das Bedienpanel. Wiederherstellen (Restore) des Backups mit Menü > Backups.</p> <p>Nicht jetzt</p> <p>Backup</p> <p>Zurück 14:22 Nächste(r)</p>
<p><input type="checkbox"/> Die Inbetriebnahme ist nun komplett und der Frequenzumrichter betriebsbereit. Mit Taste  (Done/Fertig) gelangen Sie zur Home view/Startansicht.</p>	<p>Lokal  ACS580 0.0 Hz</p> <p>Einstellungen beendet</p> <p>Antrieb ist jetzt betriebsbereit.</p> <p>Zurück 14:22 Fertig</p>
<p><input type="checkbox"/> Mit der Startansicht können die Werte der ausgewählten Signale auf dem Bedienpanel angezeigt werden.</p>	<p>Lokal  ACS580 0.0 Hz</p> <p>Ausgangsfrequenz 0.00 Hz</p> <p>Motorstrom 0.00 A</p> <p>Motordrehmoment % 0.0 %</p> <p>Optionen 14:28 Menü</p>

2 – Zusätzliche Einstellungen: zum Beispiel Makro, Rampen, Grenzwerte

- Zusätzliche Einstellungen, z.B. Makros, Rampen und Grenzwerte erfolgen über das Hauptmenü (**Main menu/Hauptmenü**), in das Sie mit Taste  (**Menu/Menü**) über Auswahl **Main menu/Hauptmenü** gelangen.
Weitere Informationen enthält der Abschnitt Inbetriebnahme (*Start-up procedure*) im Handbuch *ACS580-01 user's manual* (3AUA0000076333 [Englisch]).

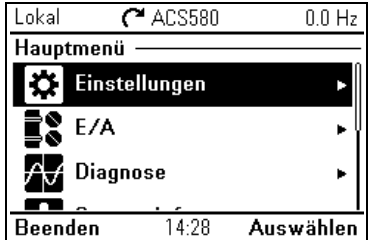

ES – Guía rápida de instalación y puesta en marcha

Esta guía le da instrucciones concretas sobre cómo instalar y poner en marcha el convertidor. Consulte la documentación completa en el *ACS580-01 user's manual* (www.abb.com/drives: Seleccione *Document Library* y busque el número de documento 3AUA0000076333 [inglés]).

Instalación

Siga estrictamente las instrucciones de seguridad



¡ADVERTENCIA! Siga estrictamente estas instrucciones. Si no lo hace, se pueden producir daños en el equipo o en las personas, e incluso causar la muerte:

- Si no es un electricista calificado, no realice ningún trabajo relacionado con la instalación eléctrica.
 - No manipule el convertidor, el cable del motor ni el motor cuando estén conectados a la red eléctrica. Si el convertidor está conectado a la corriente eléctrica, espere 5 minutos tras desconectarlo.
 - No manipule los cables de control mientras el convertidor o los circuitos de control externo reciban alimentación.
 - Asegúrese de que los restos de polvo y virutas resultantes de practicar orificios y rectificaciones no entren en el convertidor de frecuencia durante la instalación.
 - Asegúrese de que el suelo sobre el que se apoya el convertidor y la pared sobre la que está instalado son del tipo no inflamable.
-

Compruebe si es necesario reacondicionar los condensadores

Si el convertidor ha permanecido almacenado durante un año o más, debe reacondicionar los condensadores.

Puede determinar la fecha de fabricación a partir del número de serie, que encontrará en la placa de identificación adherida al convertidor. El número de serie tiene el formato MAASSRXXXX. AA y SS indican el año y la semana de fabricación, de la forma siguiente:

AA: 13, 14, 15, ... para 2013, 2014, 2015, ...

SS: 01, 02, 03,... para semana 1, semana 2, semana 3,...

Para más información sobre el reacondicionamiento de los condensadores, consulte el documento *Converter module capacitor reforming instructions* (3BFE64059629 [inglés]), disponible en Internet.

Seleccione los cables de potencia

Dimensione los cables de potencia de conformidad con los reglamentos locales para el transporte de la intensidad nominal indicada en la etiqueta de designación de tipo de su convertidor de frecuencia.

Garantice la refrigeración

Consulte las tablas *I* y *II* en la página *5* para las pérdidas. El rango de temperatura de funcionamiento permitido para el convertidor de frecuencia sin pérdida de potencia es de -15 a +40 °C. No puede existir condensación ni congelación. Para conocer las restricciones por debajo de 0 °C y por encima de +40 °C, consulte el capítulo *Technical data* en el *ACS580-01 user's manual* (3AUA0000076333 [inglés]).

ES

Proteja el convertidor y el cable de entrada de potencia

Consulte las tablas *III*, *IV* y *V* en la páginas *5* y *6* para la selección de los fusibles.

Si va a utilizar fusibles gG, compruebe la curva de tiempo-intensidad del fusible para garantizar que el tiempo de fusión del fusible sea inferior a 0,5 segundos. Siga los reglamentos locales.

Monte el convertidor de frecuencia en la pared

Consulte las figuras *A1* y *A2* en la página *3*.

Nota: Para fijar la parte inferior del convertidor solo se pueden usar dos tornillos en lugar de cuatro.

Compruebe el aislamiento de los cables de entrada y motor y del propio motor

Compruebe el aislamiento del cable de entrada de conformidad con la normativa local antes de conectarlo al convertidor de frecuencia.

Compruebe el aislamiento del cable de motor y del motor mientras el cable esté desconectado del convertidor. Mida la resistencia de aislamiento entre el conductor de cada fase y el conductor a tierra de protección con una tensión de medición de 1000 V CC. La resistencia de aislamiento de un motor ABB debe ser superior a los 100 Mohmios (valor de referencia a 25 °C o 77 °F). En cuanto a la resistencia de aislamiento de otros motores, consulte las instrucciones del fabricante.

Nota: La humedad en el interior de la carcasa del motor reduce la resistencia de aislamiento. Si sospecha de la presencia de humedad, seque el motor y repita la medición.

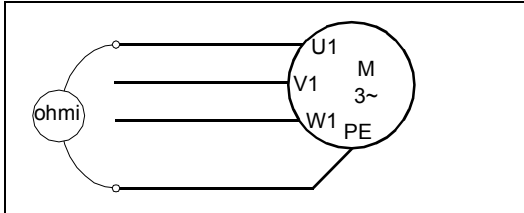

Conecte los cables de potencia

Véanse las figuras *B*, *C*, *D* y *E*. Use cable apantallado simétrico para el cableado al motor. Si el cable blindado es el único conductor de conexión a tierra de protección que tiene el convertidor o el motor, asegúrese de que tiene la conductividad suficiente como para brindar adecuadamente la función de tierra de protección.

1. Pegue el adhesivo de advertencia de tensión residual en el idioma local junto a la tarjeta de control.
2. Retire la protección de los bornes de los cables de potencia, liberando las presillas y levantando la protección por los lados con ayuda de un destornillador (2a). Haga los orificios que sean necesarios para poder pasar los cables (2b).
3. Corte los orificios correspondientes en las arandelas de goma. Deslice las arandelas por los cables. Prepare los extremos de los cables tal como se ilustra en la figura. Se muestran dos tipos diferentes de cables (3a, 3b). **Nota:** La pantalla pelada se conecta a tierra en 360 grados. Marque el extremo del cable de la pantalla con colores verde y amarillo para indicar que es el cable de protección a tierra. Pase los cables a través de los orificios del panel inferior y coloque las arandelas en los orificios (el cable del motor a la derecha y el de entrada de potencia a la izquierda).
4. Conecte el cable del motor:
 - Conecte a tierra las pantallas de los cables a 360 grados bajo las abrazaderas de conexión a tierra (4a).
 - Conecte las pantallas trenzadas de los cables a los bornes de conexión a tierra (4b).
 - Conecte los conductores de fase del cable a los bornes T1/U, T2/V y T3/W. Apriete los tornillos con el par indicado en la tabla *D* (4c).
5. Conecte los cables de entrada de potencia como en el paso 4. Conecte a tierra las pantallas de los cables a 360 grados bajo las abrazaderas de conexión a tierra (5a). Conecte las pantallas trenzadas a los bornes de conexión a tierra (5b)

y los conductores de fase a los bornes L1, L2 y L3. Apriete los tornillos con el par indicado en la tabla *D* (5c).

6. Instale la protección de EMC para separar los cables de entrada y salida.
7. Reinstale la protección en los bornes de alimentación.
8. Coloque las restantes arandelas de goma en los orificios de la placa de acceso.
9. Fije los cables fuera de la unidad de forma mecánica.
10. Conecte a tierra el apantallamiento del cable de motor en el extremo del motor. Para que las interferencias por radiofrecuencia sean mínimas, conecte a tierra la pantalla a 360 grados del cable del motor en la placa de acceso al interior de la caja de bornes del motor.

Conecte los cables de control

ES

Véase la figura *F*. Muestra un ejemplo de un cable de señal analógica y un cable de señal digital. Realice las conexiones de acuerdo con la macro que esté utilizando. Las conexiones predeterminadas de la macro estándar de ABB se muestran en el apartado *Conexiones de E/S por defecto* de la página 37.

1. Practique un orificio adecuado en la arandela de goma y pase el cable a través de ella. Pase el cable a través del orificio del panel inferior y fije la arandela en el orificio.
 2. Conecte a tierra la pantalla exterior del cable a 360° bajo la grapa de conexión a tierra. Mantenga el cable apantallado lo más cerca posible de los bornes de la tarjeta de control. Para cables de señal analógica, conecte a tierra las pantallas del par de cables y el cable de conexión a tierra al borne SCR1. Asegure los cables mecánicamente a las abrazaderas situadas debajo de la unidad de control.
 3. Coloque el cable como se muestra en la figura.
 4. Conecte los conductores a los bornes adecuados de la tarjeta de control y apriete con un par de 0,5 N·m a 0,6 N m.
 5. Ajuste todos los cables de control usando las abrazaderas de montaje de cables.
-

Conexiones de E/S por defecto

A continuación se muestran las conexiones de E/S predeterminadas de la macro estándar de ABB.

Macro estándar de ABB:

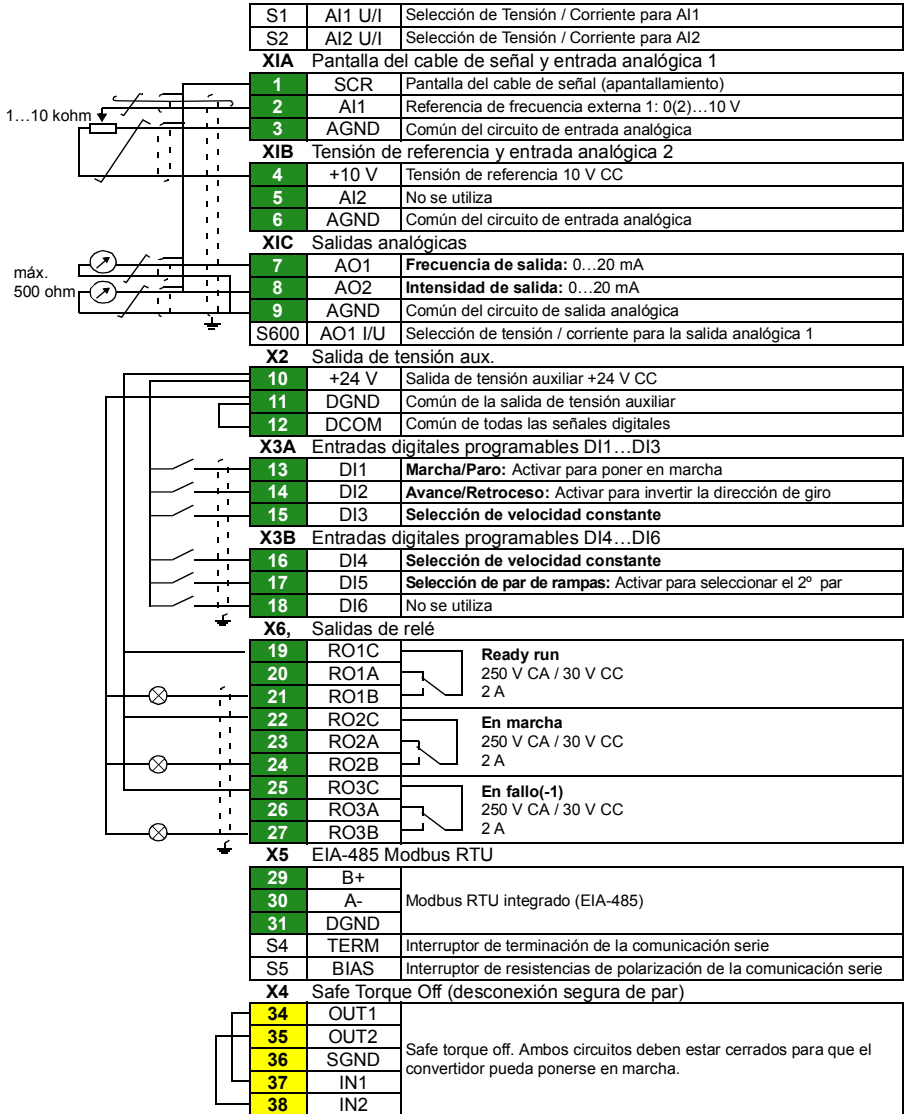

La capacidad de carga total de la salida auxiliar de tensión de +24 V (X2:10) es de 6,0 W (250 mA / 24 V).

Tamaños de hilos: 0,14...2,5 mm²(bornes +24 V, DGND, DCOM, DI, AI, AOO, AGND, RO, STO)

Pares de apriete: 0,5...0,6 N·m

Si tiene módulos opcionales, instálelos

Consulte el capítulo de *Electrical installation* en el *ACS580-01 user's manual* (3AUA0000076333 [inglés]).

Compruebe la compatibilidad con los sistemas IT (sin conexión a tierra) y redes TN (con conexión a tierra en un vértice)

ES



¡ADVERTENCIA! No instale el convertidor con el filtro EMC interno conectado a un sistema IT (un sistema de potencia sin conexión a tierra o un sistema de potencia con una gran resistencia a tierra [más de 30 ohms]) o una red TN conectada a tierra en un vértice.

Si conecta el convertidor a un sistema TN conectado a tierra en un vértice o IT (sin conexión a tierra), desconecte los filtros EMC antes de conectar el convertidor a la red de alimentación. Para saber cómo hacerlo, consulte el capítulo dedicado a la *Electrical installation* en el *ACS580-01 user's manual* (3AUA0000076333 [inglés]).

Vuelva a colocar las cubiertas

Véase la figura [G](#).

1. Vuelva a colocar la cubierta de la caja de entrada de cables.
2. Apriete los dos tornillos de sujeción con un destornillador.
3. Vuelva a colocar la cubierta del módulo. Coloque las pestañas de la cubierta superior frente a su contraparte en el bastidor y presione la cubierta.
4. Apriete los dos tornillos de sujeción con un destornillador.

Puesta en marcha











Este capítulo describe la puesta en marcha del convertidor usando el asistente de Primera puesta en marcha en el panel de control asistente.











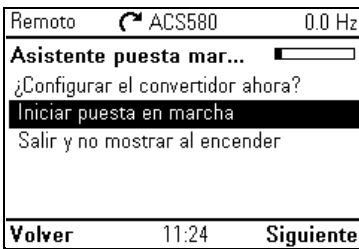

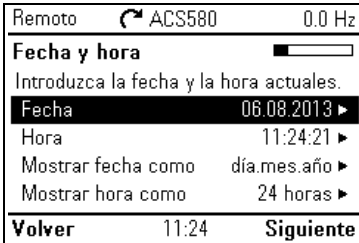

Documentación completa del firmware del convertidor: las funciones del programa, los parámetros y el análisis de errores se pueden consultar en el *ACS580-01 user's manual* (3AUA0000076333 [inglés]). Para más información sobre los paneles asistentes, consulte el *ACS-AP-x assistant control panels user's manual* (3AUA0000085685 [inglés]).

Antes de empezar

Asegúrese de que el convertidor ha sido instalado tal y como se describe en el apartado [Instalación](#) de la página 33.

Póngalo en marcha con el asistente de Primera puesta en marcha con un panel de control asistente

Seguridad																	
	Siga estrictamente las instrucciones de seguridad de la página 33 durante todo el procedimiento de puesta en marcha.																
<input type="checkbox"/>	Comprobar la instalación.																
<input type="checkbox"/>	Compruebe que la puesta en marcha del motor no suponga ningún peligro. Desacople la maquinaria accionada si existe riesgo de daños en caso de que la dirección de giro sea incorrecta.																
Sugerencias al usar el panel de control asistente:																	
<p>Los dos comandos de la parte inferior de la pantalla (a la derecha en la figura, Opciones y Menú), muestran las funciones de las dos teclas multifunción  y  situadas debajo de la pantalla. Los comandos asignados a las teclas multifunción varían en función del contexto.</p> <p>Use las teclas , ,  y  para mover el cursor y cambiar los valores en función de la vista activa.</p> <p>La tecla  muestra una página de ayuda que depende del contexto.</p>																	
1 – Asistente de Primera puesta en marcha, ajustes guiados: Idioma, fecha, hora y valores nominales del motor																	
<input type="checkbox"/>	Tenga a mano la información de la placa de datos del motor Encienda el convertidor.																
<input type="checkbox"/>	El asistente de Primera puesta en marcha le guiará durante la primera puesta en marcha. La puesta en marcha comienza automáticamente. Espere hasta que en el panel de control aparezca la pantalla de la derecha. Seleccione el idioma que quiere usar resaltándolo y pulsando  (OK).																
	<table border="1" style="width: 100%;"> <tr> <td style="padding: 5px;">Deutsch</td> <td style="border: none;"></td> </tr> <tr> <td style="padding: 5px;">Suomi</td> <td style="border: none;"></td> </tr> <tr> <td style="padding: 5px;">Français</td> <td style="border: none;"></td> </tr> <tr> <td style="padding: 5px;">Italiano</td> <td style="border: none;"></td> </tr> <tr> <td style="padding: 5px;">Nederlands</td> <td style="border: none;"></td> </tr> <tr> <td style="padding: 5px;">Svenska</td> <td style="border: none;"></td> </tr> <tr> <td style="padding: 5px; background-color: black; color: white;">Español</td> <td style="border: none;"></td> </tr> <tr> <td style="border: none;"></td> <td style="text-align: right; padding: 5px;">OK ▶</td> </tr> </table>	Deutsch		Suomi		Français		Italiano		Nederlands		Svenska		Español			OK ▶
Deutsch																	
Suomi																	
Français																	
Italiano																	
Nederlands																	
Svenska																	
Español																	
	OK ▶																

<p><input type="checkbox"/> Resalte el parámetro Iniciar puesta en marcha (si no está resaltado) y pulse  (Siguiente).</p>	
<p><input type="checkbox"/> Establezca la fecha y la hora y el formato de fecha y hora que desea usar.</p> <ul style="list-style-type: none"> • Pulse  para ir a la vista de edición de la fila resaltada. • Desplace la información de la pantalla con las teclas  y . <p>Pase a la siguiente vista pulsando  (Siguiente).</p>	
<p><input type="checkbox"/> En una vista de edición:</p> <ul style="list-style-type: none"> • Use  y  para mover el cursor hacia la izquierda y la derecha. • Use  y  para cambiar el valor. • Pulse  (Guardar) para aceptar el nuevo ajuste o pulse  (Cancelar) para volver a la vista anterior sin hacer cambios. 	
<p><input type="checkbox"/> Para darle al convertidor un nombre que aparecerá en la parte superior, pulse . Si no desea cambiar el nombre predeterminado (ACS580), vaya directamente a la configuración de los valores nominales del motor pulsando  (Siguiente).</p> <p>Para más información sobre la edición de texto, consulte el <i>ACS580-01 user's manual</i> (3AUA0000076333 [Inglés]) o el <i>ACS-AP-x assistant control panels user's manual</i> (3AUA0000085685 [Inglés]).</p>	

Consulte la placa de características del motor para conocer los siguientes valores nominales del motor. Siempre que sea posible, introduzca los valores exactamente de la forma mostrada en la placa de características del motor.

Ejemplo de placa de características de un motor de inducción (asíncrono):

ABB Motors							
3 ~ motor		M2AA 200 MLA 4					
IEC 200 M/L 55							
No							
Ins.cl. F				IP 55			
V	Hz	kW	r/min	A	cos φ	IΔ/IN	fE/s
690 Y	50	30	1475	32.5	0.83		
400 D	50	30	1475	56	0.83		
660 Y	50	30	1470	34	0.83		
380 D	50	30	1470	59	0.83		
415 D	50	30	1475	54	0.83		
440 D	60	35	1770	59	0.83		
Cat. no 3GAA 202 001 - ADA							
6312/C3		6210/C3		180 kg			
IEC 34-1							

ES

- Compruebe que los datos del motor sean correctos. Los valores están predefinidos según el tamaño del convertidor pero usted debe verificar que se corresponden con los del motor. Empiece por la corriente nominal del motor. El valor nominal del coseno φ y del par son opcionales. Pulse (**Siguiente**) para continuar.

Remoto ACS580 0.0 Hz

Valores nominales mo...

Busque los valores en la placa de características del motor e introdúzcalos aquí:

Intensidad Nominal Motor 1.8 A

Tension Nominal Motor 400.0 V

Volver 11:24 Siguiente

- Para hacer la prueba de dirección, resalte **Girar el motor** y pulse (**Siguiente**).

Remoto ACS580 0.0 Hz

¿Prueba de dirección?

¿Girar el motor para comprobar la dirección?

Ahora no

Girar el motor

Volver 11:26 Siguiente

- Primero cambie a control local pulsando la tecla . El control local se indica con el texto "Local" en el panel superior. A continuación pulse la tecla **Marcha** en el panel, para poner en marcha el convertidor.

















Local ACS580 0.0 Hz

Pulse Marcha

Alarma: hasta que no acabe la configuración, las medidas de seguridad no están activas y la velocidad del motor es 5 Hz.

Pulse Marcha ahora para hacer girar

Volver 11:26

<p><input type="checkbox"/> Compruebe la dirección de giro del motor. Si gira hacia adelante, resalte (si no está resaltado) Sí, el motor gira hacia adelante y pulse  (Siguiente) para continuar. Si no, resalte No, cambiar dirección y pulse  (Siguiente) para continuar.</p>	<p>Local  ACS580 5.0 Hz</p> <p>¿Esto es hacia adelan... </p> <p>Si selecciona "No, cambiar dirección" le indica al convertidor que la cambie y define la nueva como "adelante".</p> <p>Sí, el motor gira hacia adelante</p> <p>No, cambiar dirección</p> <hr/> <p>Volver 11:27 Siguiente</p>
<p><input type="checkbox"/> Si quiere hacer una copia de seguridad de los ajustes hechos hasta ahora, seleccione Backup y pulse  (Siguiente). Si no quiere hacer una copia de seguridad, seleccione Ahora no y pulse  (Siguiente).</p>	<p>Local  ACS580 0.0 Hz</p> <p>¿Hacer backup? </p> <p>Copia todos los ajustes del archivo de backup guardado en panel de control. Para restaurarlo use Menú > Backups.</p> <p>Ahora no</p> <p>Backup</p> <hr/> <p>Volver 11:27 Siguiente</p>
<p><input type="checkbox"/> Ahora la configuración está terminada y el convertidor está listo para usar. Pulse  (Hecho) para ir a la vista Inicio.</p>	<p>Local  ACS580 0.0 Hz</p> <p>Puesta marcha compl...</p> <p>Convertidor listo para su uso.</p> <hr/> <p>Volver 11:27 Hecho</p>
<p><input type="checkbox"/> En el panel se muestra la vista Inicio con la monitorización de los valores de las señales seleccionadas.</p>	<p>Local  ACS580 0.0 Hz</p> <p>Frecuencia Salida 0.00 Hz</p> <p>Intensidad Motor 0.00 A</p> <p>Par motor % 0.0 %</p> <hr/> <p>Opciones 11:29 Menú</p>
<p>2 – Ajustes adicionales: por ejemplo macro, rampas, límites</p>	
<p><input type="checkbox"/> Para realizar ajustes adicionales como macros, rampas y límites comenzando desde el Menú principal, pulse  (Menú) para ir al Menú principal. Para más información, consulte el procedimiento de puesta en marcha en el <i>ACS580-01 user's manual</i> (3AUA0000076333 [inglés]).</p>	<p>Local  ACS580 0.0 Hz</p> <p>Menú principal</p> <p> Ajustes ▶</p> <p> I/O ▶</p> <p> Diagnósticos ▶</p> <hr/> <p>Salir 11:29 Seleccionar</p>

FI – Asennuksen ja käytön aloituksen pikaopas

Tässä oppaassa kuvataan lyhyesti taajuusmuuttajan asennus ja käyttöönotto. Täydelliset tiedot löytyvät oppaasta *AS580-01 user's manual* (www.abb.com/drives: valitse *Document Library* ja kirjoita hakukenttään dokumentin numero 3AUA0000076333 [englanninkielinen]).

Asennus

Noudata turvaohjeita



VAROITUS! Noudata näitä ohjeita. Niiden huomiotta jättämisestä voi aiheutua loukkaantumisen, kuoleman tai laitteiston vahingoittuminen.

- Jos et ole pätevä sähköalan ammattilainen, älä tee sähköasennustöitä.
- Tee kaikki taajuusmuuttajan, moottorikaapelin ja moottorin asennus- ja huoltotyöt jännitteen ollessa katkaistuna. Jos taajuusmuuttaja on kytketty verkkoon, kytke se irti verkosta ja odota 5 minuuttia.
- Älä käsittele ohjauskaapeleita verkkojännitteen ollessa kytkettynä taajuusmuuttajaan tai ulkoisiin ohjauspiireihin.
- Varmista, ettei poraus- tai hiomajäte pääse laitteen sisään asennuksen yhteydessä.
- Varmista, että taajuusmuuttajan alla oleva lattia ja seinä, johon taajuusmuuttaja on asennettu, ovat syttymättömiä.

FI

Tarkista, tarvitseeko kondensaattorit elvyttää

Jos taajuusmuuttaja on varastoitu vuoden ajan tai pidempään, kondensaattorit on elvytettävä.

Voit selvittää valmistusajankohdan sarjanumeron perusteella. Sarjanumero on taajuusmuuttajaan kiinnitettyssä tyyppikilvessä. Sarjanumero on muotoa MYYWWRXXXX. YY ja WW ilmaisevat valmistusvuoden ja -viikon seuraavasti:

YY: 13, 14, 15, ..., mikä tarkoittaa vuotta 2013, 2014, 2015, ...

WW: 01, 02, 03, ..., mikä tarkoittaa viikkoa 1, 2, 3, ...

Lisätietoja kondensaattorien elvyttämisestä on Internetissä julkaistussa *Converter module capacitor reforming instructions* -oppaassa (3BFE64059629, [englanninkielinen]).

Valitse tehokaapelit

Mitoita tehokaapelit paikallisten säännösten mukaisesti siirtämään taajuusmuuttajan tyyppikilvessä ilmoitettua nimellisivirtaa.

Varmista jäähdytys

Lisätietoja häviöistä on taulukoissa I ja II sivulla 5. Taajuusmuuttajan sallittu käyttölämpötila-alue ilman kertoimia on $-15...+40$ °C. Tiivistyminen ja huurtuminen eivät ole sallittuja. Rajoitukset, jotka koskevat alle 0 °C:een ja yli +40 °C:een lämpötilaa, on kuvattu oppaan ACS580-01 user's manual (3AUA0000076333 [englanninkielinen]) luvussa *Technical data*.

Suojaa taajuusmuuttaja ja syöttökaapeli

Tietoja sulakkeista on taulukoissa III, IV ja V sivuilla 5 ja 6.

Jos aiot käyttää gG-sulakkeita, tarkista sulakkeen virta-aikaominaiskäyrästä, että sulakkeen toiminta-aika on alle 0,5 sekuntia. Noudata paikallisia määräyksiä.

FI

Asenna taajuusmuuttaja seinälle

Katso kuvat A1 ja A2 sivulla 3.

Huomautus: Voit käyttää vain kahta ruuvia neljän sijaan taajuusmuuttajan alaosan kiinnittämiseen.

Tarkista syöttö- ja moottorikaapelien sekä moottorin eristys

Tarkista syöttökaapelin eristys paikallisten määräysten mukaisesti ennen kaapelin kytkemistä taajuusmuuttajaan.

Varmista moottorikaapelin ja moottorin eristys, kun kaapeli on irti taajuusmuuttajasta. Mittaa jokaisen vaihejohtimen ja suojamaajohtimen välinen eristysvastus 1 000 VDC:n mittausjännitteellä. ABB:n moottoreiden eristysvastuksen tulee olla yli 100 megaohmia (ohjearvo lämpötilassa 25 °C). Lisätietoja muiden moottorien eristysvastuksista on valmistajan ohjeissa.

Huomautus: Moottorin kotelon sisällä oleva kosteus pienentää eristysvastusta. Jos epäilet, että kotelon sisällä on kosteutta, kuivata moottori ja toista toimenpide.

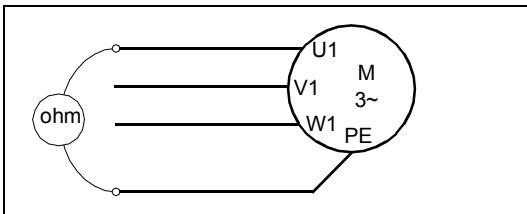

Kytke tehokaapelit

Katso kuvat *B*, *C*, *D* ja *E*. Käytä suojattua symmetristä moottorikaapelia. Jos kaapelin suojavaippa on taajuusmuuttajan tai moottorin ainoa PE-johdin, varmista, että sillä on riittävä johtavuus PE:tä varten.

1. Kiinnitä oikeankielinen jäännösjännitteen varoitustarra ohjauskortin viereen.
2. Irrota suoja tehokaapelien liittimistä irrottamalla pidikkeet ja nostamalla suojaa reunoista ruuvitaltalla (2a). Leikkaa aukot asennettaville kaapeleille (2b).
3. Leikkaa sopivankokoiset reiät kumitiivisteisiin. Vedä tiivisteet kaapeleiden päälle. Valmistele kaapelien päät kuvassa esitetyllä tavalla. Kaksi erilaista kaapelityyppiä on esitetty (3a, 3b). **Huomautus:** Paljas vaippa maadoitetaan 360 astetta. Merkitse suojavaipasta tehty punos PE-johtimeksi keltavihreällä värillä. Liu'uta kaapelit pohjalevyn reikien läpi ja kiinnitä tiivisteet reikiin (moottorikaapeli oikeanpuoleiseen ja syöttökaapeli vasemmanpuoleiseen).
4. Kytke moottorikaapeli:
 - Maadoita suojavaippa 360 astetta maadoituskiinnikkeiden alta (4a).
 - Kytke kaapelin kierretty suojavaippa maadoitusliittimeen (4b).
 - Kytke kaapelin vaihejohtimet T1/U-, T2/V- ja T3/W-liittimiin. Kiristä ruuvit taulukossa *D* annettuun momenttiin (4c).
5. Kytke syöttökaapeli vaiheessa **4** kuvatulla tavalla. Maadoita suojavaippa 360 astetta maadoituskiinnikkeiden alta (5a). Kytke kierretty suojavaippa maadoitusliittimeen (5b) ja vaiheliittimet L1-, L2- ja L3-liittimiin. Kiristä ruuvit taulukossa *D* annettuun momenttiin (5c).
6. Asenna tulo- ja lähtökaapelit erottava EMC-suoja.
7. Asenna teholiittimien suoja takaisin paikalleen.
8. Pane käyttämättömät kumitiivisteet läpivientilevyn reikiin.
9. Kiinnitä kaapelit yksikön ulkopuolella mekaanisesti.
10. Maadoita moottorikaapelin suojavaippa moottorin päästä. Vähennä radiotaajuisia häiriöitä maadoittamalla moottorikaapelin suojavaippa 360 astetta moottorin kytKentäkotelon läpiviennissä.

Kytke ohjauskaapelit

Katso kuva [F](#). Siinä näkyy esimerkki yhdestä analogia- ja yhdestä digitaalisignaali-kaapelista. Tee kytkennät käytössä olevan makron mukaisesti. Vakio-ohjausmakron oletuskytkennät on esitetty kohdassa [Oletusarvoiset I/O-ohjauskytkennät](#) sivulla [49](#).

1. Leikkaa kumitiivisteeseen sopivan kokoinen reikä ja liu'uta kumitiiviste kaapeliin. Vie kaapeli pohjalevyssä olevan reiän läpi ja kiinnitä tiiviste reikään.
2. Maadoita kaapelin ulompi suojavaippa 360 astetta maadoitusliittimen alta. Pidä kaapeli kuorimattomana niin lähelle ohjauskortin liittimiä kuin mahdollista. Maadoita myös analogiasignaali-kaapelien parikaapelin suojavaipat ja maadoitusjohdin SCR1-liittimen kohdalla. Kiinnitä kaapelit mekaanisesti ohjausyksikön alla oleviin kiinnikkeisiin.
3. Reitä kaapeli kuvassa esitetyllä tavalla.
4. Kytke johtimet oikeisiin ohjauskortin liittimiin ja kiristä momenttiin 0,5...0,6 Nm.
5. Sido kaikki ohjauskaapelit sidontakiinnikkeisiin.

Oletusarvoiset I/O-ohjauskytkennät

Alla on esitetty vakio-ohjausmakron oletusarvoiset I/O-kytkennät.

Vakio-ohjausmakro:

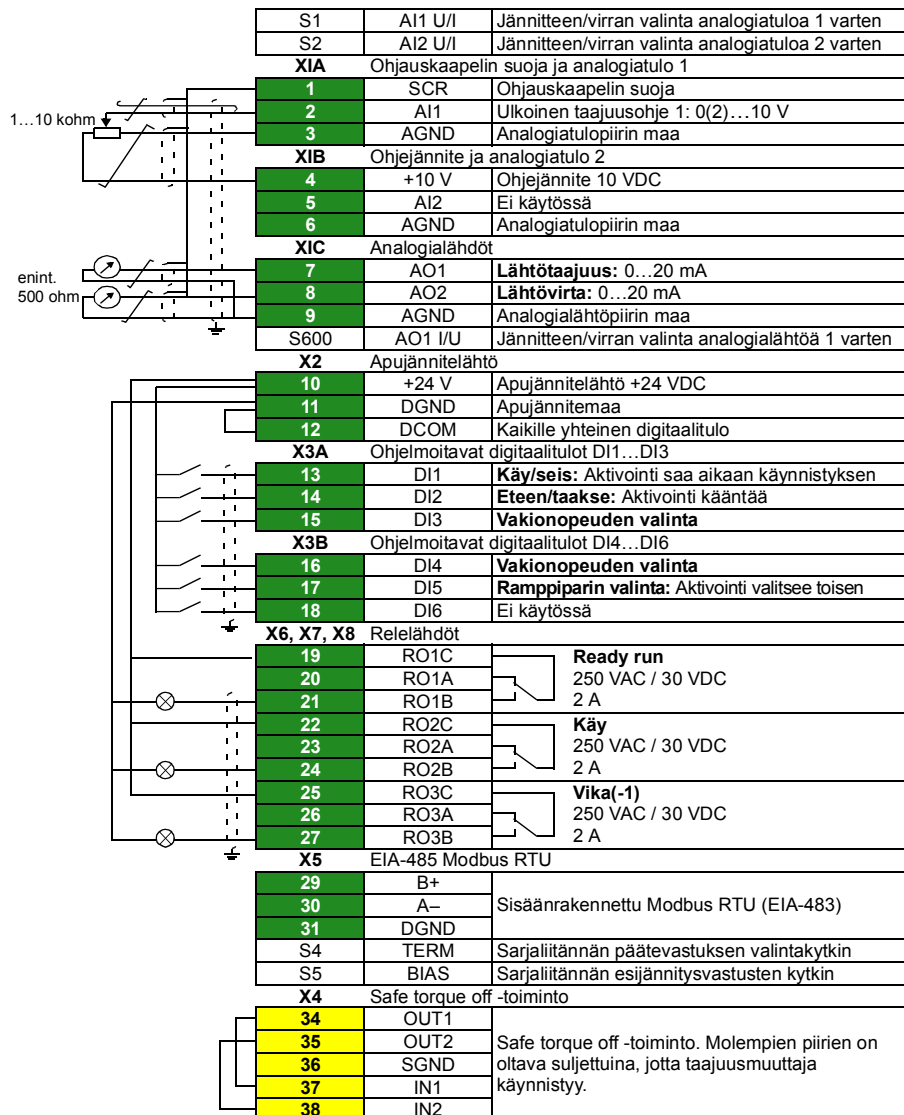

Apujännitelähdön +24 V (X2:10) kokonaiskuormitettavuus on 6,0 W (250 mA / 24 V).
Johdinkoot: 0,14...2,5 mm²(liittimet +24 V, DGND, DCOM, DI, AI, AOO, AGND, RO, STO)
Kirstysmomentit: 0,5...0,6 Nm

Asenna mahdolliset lisävarustemoduulit

Katso oppaan *ACS580-01 user's manual* (3AUA0000076333 [englanninkielinen]) luku *Electrical installation*.

Tarkista yhteensopivuus maadoittamattomien IT-verkkojen ja epäsymmetrisesti maadoitettujen TN-verkkojen kanssa



VAROITUS! Älä asenna taajuusmuuttajaa niin, että sisäinen EMC-suodatin on kytketty IT-verkkoon (maadoittamattomaan verkkoon tai suurohmisesti [yli 30 ohmia] maadoitettuun verkkoon) tai epäsymmetrisesti maadoitettuun TN-verkkoon.

FI

Jos kytket taajuusmuuttajan maadoittamattomaan IT-verkkoon tai epäsymmetrisesti maadoitettuun TN-verkkoon, kytke EMC-suodattimet irti, ennen kuin kytket taajuusmuuttajan syöttöverkkoon. Ohjeita tähän on oppaan *ACS580-01 user's manual* (3AUA0000076333 [englanninkielinen]) luvussa *Electrical installation*.

Asenna kannet takaisin paikoilleen

Katso kuva [G](#).

1. Asenna kaapelin läpivientikotelon kansi.
 2. Kiristä kaksi kiinnitysruuvia ruuvitaltalla.
 3. Asenna moduulin kansi takaisin paikalleen. Pane kannen yläosan ulokkeet kotelon vastakappaleisiin ja paina sitten kantta.
 4. Kiristä kaksi kiinnitysruuvia ruuvitaltalla.
-

Käynnistys

Tässä luvussa kuvataan taajuusmuuttajan käynnistäminen Assistant-ohjauspaneelin ensimmäisen käynnistykseen assistantin avulla.









Kattavat tiedot taajuusmuuttajan ohjelmistosta (ohjelmisto-ominaisuuksista, parametreista ja vianetsinnästä) on oppaassa *AS580-01 user's manual* (3AUA0000076333 [englanninkielinen]). Lisätietoja Assistant-ohjauspaneelista on oppaassa *ACS-AP-x assistant control panels user's manual* (3AUA0000085685 [englanninkielinen]).

Ennen käynnistystä





















Varmista, että taajuusmuuttaja on asennettu kohdassa [Asennus](#) sivulla [45](#) kuvatulla tavalla.

Käynnistys käyttämällä Assistant-paneelin ensimmäisen käynnistykseen assistanttia















FI

Turvallisuus	
	Noudata käynnistykseen aikana sivulla 45 annettuja turvallisuusohjeita.
<input type="checkbox"/>	Tarkista asennus.
<input type="checkbox"/>	Varmista, että moottorin käynnistäminen ei aiheuta vaaraa. Kytke käytettävä laite irti , jos väärä pyörimissuunta voi vaurioittaa käytettävää laitetta.
Vihjeitä Assistant-ohjauspaneelin käyttöön	
<p>Näytön alareunan kaksi komentoa (oikealla olevassa kuvassa Valinnat ja Valikko) osoittavat näytön alla olevien kahden valintapainikkeen  ja  toiminnot. Valintapainikkeilla annettavat komennot vaihtelevat tilanteen mukaan.</p> <p>Painikkeilla , ,  ja  voidaan siirtää kohdistinta ja/tai muuttaa arvoja aktiivisen näkymän mukaan.</p> <p>Painike  näyttää tilannekohtaisen ohjesivun.</p>	

1 – Ensimmäisen käynnistyksen assistantin ohjatut asetukset: Kieli, päivämäärä ja aika sekä moottorin nimellisarvot

<input type="checkbox"/> Varmista, että moottorin arvokilven tiedot ovat saatavilla. Kytke taajuusmuuttajan virta.	
<input type="checkbox"/> Ensimmäisen käynnistyksen assistantti opastaa sinut ensimmäisen käynnistyksen läpi. Käynnistys alkaa automaattisesti. Odota, kunnes ohjauspaneeliin aukeaa oikealla näkyvä näkymä. Valitse kieli, jota haluat käyttää, korostamalla se ja painamalla  (OK) -painiketta.	<div style="border: 1px solid black; padding: 5px;"> <p>English Deutsch Suomi Français Italiano Nederlands Svenska</p> <p style="text-align: right;">OK ▶</p> </div>
<input type="checkbox"/> Korosta vaihtoehto Aloita käyttöönotto (jos sitä ei ole jo korostettu) ja paina  (Seuraava) -painiketta.	<div style="border: 1px solid black; padding: 5px;"> <p>Kauko  ACS580 0.0 Hz</p> <p>Käyttöönottoassistentti </p> <p>Haluatko suorittaa taajuusmuuttajan käyttöönoton?</p> <p>Aloita käyttöönotto</p> <p>Lopeta, älä näytä uudestaan</p> <hr/> <p>Takaisin 10:29 Seuraava</p> </div>
<input type="checkbox"/> Aseta päivämäärä, aika sekä päivämäärän ja ajan esitysmuodot. <ul style="list-style-type: none"> • Voit siirtyä korostettuna näkyvän rivin muokkaustilaan painamalla  -painiketta. • Voit selata tekstiä  - ja  -painikkeilla. Voit siirtyä seuraavaan näkymään painamalla  (Seuraava) -painiketta.	<div style="border: 1px solid black; padding: 5px;"> <p>Kauko  ACS580 0.0 Hz</p> <p>Päivämäärä ja kellona... </p> <p>Anna tämänhetkinen päivämäärä ja kellonaika.</p> <p>Päiväys 06.08.2013 </p> <p>Aika 10:30:00 </p> <p>Päivämäärän näyttö... päivä.kuuka... </p> <hr/> <p>Takaisin 10:30 Seuraava</p> </div>
<input type="checkbox"/> Muokkausnäkyssä: <ul style="list-style-type: none"> • Siirrä kohdistinta vasemmalle ja oikealle  - ja  -painikkeilla. • Muuta arvoa  - ja  -painikkeilla. • Voit hyväksyä uuden asetuksen painamalla  (Tallenna) -painiketta tai palata edelliseen näkymään tekemättä muutoksia painamalla  (Peruuta) -painiketta. 	<div style="border: 1px solid black; padding: 5px;"> <p>Kauko  ACS580 0.0 Hz</p> <p>Päiväys</p> <p>Päivä Kuuk. Vuosi</p> <p>06.08.2013</p> <p>Tiistai</p> <hr/> <p>Peruuta 10:30 Tallenna</p> </div>

<input type="checkbox"/> Voit antaa taajuusmuuttajalle nimen, joka näkyy ylimpänä, painamalla -painiketta. Jos et halua muuttaa oletusnimeä (ACS580), jatka suoraan moottorin nimellisarvojen asettamiseen painamalla (Seuraava) -painiketta. Tietoja tekstin muokkaamisesta on oppaissa <i>ACS580-01 user's manual</i> (3AUA0000076333 [englanninkielinen]) ja <i>ACS-AP-x assistant control panels user's manual</i> (3AUA0000085685 [englanninkielinen]).	Kauko ACS580 0.0 Hz Taajuusmuuttajan nimi Nimi näkyy ohjauspaneelinäytön yläreunassa. Tämä auttaa näkemään, mitä moottoria tämä taajuusmuuttaja ohjaa. Taajuusmuuttajan nimi ACS580 Takaisin 10:30 Seuraava
Tarkista seuraavat moottorin nimellisarvojen asetukset moottorin arvokilvestä. Syötä arvot <u>tarkalleen</u> moottorin arvokilvestä kuvatulla tavalla, mikäli mahdollista.	
Esimerkki epätahtimoottorin arvokilvestä: 	
<input type="checkbox"/> Tarkista, että moottorin tiedot ovat oikein. Arvot on määritetty ennalta taajuusmuuttajan koon perusteella, mutta tulee tarkistaa, että ne vastaavat moottoria. Aloita moottorin nimellisvirrasta. Moottorin nimellinen cos ϕ ja nimellismomentti ovat valinnaisia. Jatka painamalla (Seuraava) -painiketta.	Kauko ACS580 0.0 Hz Moottorin nimellisarvot Etsi arvot moottorin arvokilvestä ja syötä ne tähän: Moottorin nimellisvirta 1.8 A Moottorin nimellisjännite 400.0 V Moottorin nimellistaajuus 50.00 Hz Takaisin 10:30 Seuraava
<input type="checkbox"/> Voit tehdä suuntatestin korostamalla Pyöritä moottoria -vaihtoehdon ja painamalla (Seuraava) -painiketta.	Kauko ACS580 0.0 Hz Suuntatesti? Tarkistetaanko suunta pyörittämällä moottoria? Ei nyt Pyöritä moottoria Takaisin 10:32 Seuraava

<input type="checkbox"/> Siirry ensin paikallishjaukseen painamalla LocRem -painiketta. Paikallishjauus on ilmaistu näytön yläreunassa näkyvällä Paikallinen-tekstillä. Käynnistä sitten taajuusmuuttaja painamalla paneelin käynnistyspainiketta  .	<div style="border: 1px solid black; padding: 5px;"> Paikalli...  ACS580 0.0 Hz Valitse Käynnistä  Varoitus! Ennen kuin käyttöönnotto on suoritettu, turvatoiminnot eivät ole käytössä ja moottorin nopeus on 5 Hz. Pyöräytä moottoria valitsemalla Käynnistä ja tarkista sitten Takaisin 10:33 </div>
<input type="checkbox"/> Tarkista moottorin suunta. Jos se on eteenpäin, korosta vaihtoehto Kyllä, moottori pyörii eteenpäin (jos sitä ei ole jo korostettu) ja jatka painamalla  (Seuraava) -painiketta. Jos suunta ei ole eteenpäin, korosta vaihtoehto Ei, korjaa suunta ja jatka painamalla  (Seuraava) -painiketta.	<div style="border: 1px solid black; padding: 5px;"> Paikalli...  ACS580 5.0 Hz Onko suunta eteenpäin?  Valinta "Ei, korjaa suunta" saa taajuusmuuttajan muuttamaan suuntaa. Uusi suunta on "eteenpäin". Kyllä, moottori pyörii eteenpäin Ei, korjaa suunta Takaisin 10:33 Seuraava </div>
<input type="checkbox"/> Jos haluat varmuuskopioida jo tehdyt asetukset, valitse vaihtoehto Ota varmuuskopio ja paina  (Seuraava) -painiketta. Jos et halua ottaa varmuuskopiota, valitse vaihtoehto Ei nyt ja paina  (Seuraava) -painiketta.	<div style="border: 1px solid black; padding: 5px;"> Paikalli...  ACS580 0.0 Hz Tehdäänkö varmuusko...  Kopioi kaikki asetukset ohjauspaneeliin tallennettuun varmuuskopiotiedostoon. Palautus: Valikko > Varmuuskopiot. Ei nyt Ota varmuuskopio Takaisin 10:33 Seuraava </div>
<input type="checkbox"/> Käyttöönnotto on nyt valmis ja taajuusmuuttaja on valmis käytettäväksi. Palaat kotinäyttöön painamalla  (Valmis) -painiketta.	<div style="border: 1px solid black; padding: 5px;"> Paikalli...  ACS580 0.0 Hz Käyttöönnotto on valmis Taajuusmuuttaja on käyttövalmis. Takaisin 10:33 Valmis </div>
<input type="checkbox"/> Paneelissa näkyy kotinäyttö, jossa valvotaan valittujen signaalien arvoja.	<div style="border: 1px solid black; padding: 5px;"> Paikalli...  ACS580 0.0 Hz Lähtötaajuus 0.00 Hz Moottorin virta 0.00 A Moottorin momentti % 0.0 % Valinnat 10:37 Valikko </div>

2 – Lisäasetukset, esimerkiksi makro, rampit, rajat

- Voit määrittää tarvittavat lisäasetukset, kuten makron, ramppien ja rajojen asetukset aloittamalla päävalikosta. Siirry päävalikkoon painamalla  (**Valikko**) -painiketta.
- Lisätietoja on oppaan *ACS580-01 user's manual* (3AUA0000076333 [englanninkielinen]) käynnistysohjeissa.



FR – Guide d'installation et de mise en route

Ce guide présente de façon succincte l'installation et la mise en route de l'appareil. Pour la procédure détaillée, cf. document anglais *ACS580-01 user's manual* (www.abb.com/drives: sélectionnez *Document Library* (vous devrez peut-être afficher la page en anglais pour voir cette rubrique) et recherchez le document anglais numéro 3AUA0000076333).

Installation

Consignes de sécurité.



ATTENTION ! Vous devez suivre les consignes de sécurité à la lettre. Leur non-respect est susceptible de provoquer des blessures graves, voire mortelles, ou des dégâts matériels.

- Seul un électricien qualifié est autorisé à effectuer les raccordements électriques.
 - N'intervenez jamais sur le variateur, le moteur ou son câblage sous tension. S'il est déjà raccordé au réseau, vous devez attendre 5 minutes après sectionnement de l'alimentation avant d'intervenir.
 - Vous ne devez pas intervenir sur les câbles de commande lorsque le variateur ou les circuits de commande externes sont sous tension.
 - En cas de perçage ou de rectification d'un élément, évitez toute pénétration de débris dans le variateur.
 - Assurez-vous que le sol sous le variateur ainsi que la paroi de fixation sont en matériau ininflammable.
-

FR

Vérification des condensateurs

Si le variateur est resté entreposé pendant un an ou plus, vous devez réactiver les condensateurs.

Pour connaître la date de fabrication, consultez le numéro de série, qui se trouve sur la plaque signalétique de l'appareil. Le numéro de série est au format MAASSRXXXX, avec AA et SS indiquant respectivement l'année et la semaine de fabrication :

AA : 13, 14, 15, ... = 2013, 2014, 2015, ...

SS : 01, 02, 03, ... = semaine 1, semaine 2, semaine 3, ...

Pour la procédure de réactivation, cf. document anglais *Convert module capacitor reforming instructions* (3BFE64059629), disponible sur Internet.

Sélection des câbles de puissance

Les câbles de puissance doivent être dimensionnés en fonction de la réglementation locale pour supporter le courant nominal indiqué sur la plaque signalétique du variateur.

Refroidissement

Cf. tableaux *I* et *II* page *5* pour les valeurs de perte. Sans déclassement, la plage de température de fonctionnement admissible va de -15 à +40 °C (de +5 à +104 °F). Condensation ou givre interdits. Pour les restrictions à des températures inférieures à 0 °C (+32 °F) ou supérieures à +40 °C (+104 °F), cf. chapitre *Technical data* du manuel anglais *ACS580-01 user's manual* (3AUA0000076333).

Protection du variateur et du câble réseau

Cf. tableaux *III*, *IV* et *V* pages *5* et *6* pour les fusibles.

FR

Si vous prévoyez d'utiliser des fusibles gC, vérifiez sur la courbe temps-courant que le temps de manœuvre du fusible est inférieur à 0,5 seconde. Respectez la réglementation locale.

Montage mural du variateur

Cf. figures *A1* et *A2* page *3*.

N.B. : Il est possible de n'utiliser que deux vis au lieu de quatre pour fixer la partie inférieure du variateur.

Mesure de la résistance d'isolement du câble réseau, du moteur et de son câblage

Mesurez la résistance d'isolement du câble réseau avant de le brancher sur le variateur conformément à la réglementation en vigueur.

Mesurez la résistance d'isolement du moteur et de son câblage lorsqu'il est sectionné du variateur. Mesurez la résistance d'isolement du câble moteur entre chaque phase et la terre de protection (PE) avec une tension de mesure de 1000 Vc.c. Les valeurs mesurées sur un moteur ABB doivent être supérieures à 100 Mohm (valeur de référence à 25 °C ou 77 °F). Pour la résistance d'isolement des autres moteurs, consultez les consignes du fabricant.

N.B. : La présence d'humidité à l'intérieur de l'enveloppe du moteur réduit sa résistance d'isolement. Si vous soupçonnez la présence d'humidité, séchez le moteur et recommencez la mesure.

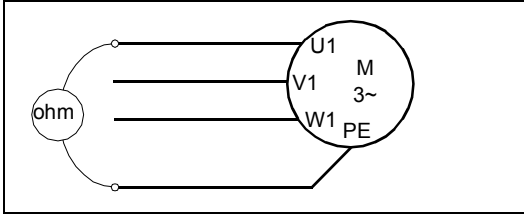

Raccordement des câbles de puissance

Cf. figures **B**, **C**, **D** et **E**. Utilisez un câble moteur symétrique blindé. Si le blindage du câble constitue le seul conducteur PE du variateur ou du moteur, vérifiez que sa conductivité est suffisante pour assurer la protection.

1. Vous devez fixer une étiquette de mise en garde contre les tensions résiduelles dans votre langue à côté de la carte de commande.
2. Ôtez la protection des bornes de puissance en enfonçant les clips et en la soulevant avec un tournevis par les côtés (2a). Percez les ouvertures pour le passage des câbles (2b).
3. Découpez des trous de diamètre adéquat dans les passe-câbles en caoutchouc pour les glisser sur les câbles. Préparez les extrémités des câbles comme illustré sur la figure. Deux types de câbles différents sont illustrés (3a, 3b). **N.B.** : Vous devrez effectuer une reprise de masse sur 360° du blindage nu. Marquez la queue de cochon du blindage en jaune et vert pour indiquer qu'il s'agit du conducteur PE. Faites passer les câbles dans les perçages de la plaque du fond et fixez les passe-câbles dessus (câble moteur à droite et câble réseau à gauche).
4. Raccordez le câble moteur :
 - Effectuez une reprise de masse sur 360° du blindage sous les colliers de terre (4a).
 - Raccordez le blindage torsadé du câble à la borne de terre (4b).
 - Raccordez les conducteurs de phase du câble aux bornes T1/U, T2/V et T3/W. Serrez les vis au couple indiqué dans le tableau **D** (4c).
5. Raccordez le câble réseau comme à l'étape **4**. Effectuez une reprise de masse sur 360° du blindage sous les colliers de terre (5a). Raccordez le blindage

torsadé à la borne de terre (5b) et les conducteurs de phase aux bornes L1, L2 et L3. Serrez les vis au couple indiqué dans le tableau *D* (5c).

6. Montez la protection RFI qui sépare les câbles c.a. des câbles c.c.
7. Remplacez la protection des bornes de puissance.
8. Placez les passe-câbles en caoutchouc non utilisés sur les perçages de la plaque passe-câbles.
9. Fixez mécaniquement les câbles à l'extérieur du variateur.
10. Mettez à la terre le blindage du câble moteur du côté moteur. Pour minimiser les perturbations HF, effectuez une reprise de masse sur 360° du blindage du câble moteur en entrée de la boîte à bornes du moteur

Raccordement des câbles de commande

Cf. figure *F* pour un exemple avec un câble de signaux analogiques et un câble de signaux logiques. Raccordez les câbles selon le macroprogramme utilisé. Les pré-réglages usine du macroprogramme Standard ABB sont indiqués à la section *Raccordement des signaux d'E/S (pré-réglages)* page 62.

1. Découpez un trou de diamètre adéquat dans le passe-câbles en caoutchouc pour le glisser sur le câble. Insérez le câble dans le trou de la plaque inférieure et fixez-y le passe-câbles.
2. Effectuez une reprise de masse sur 360° du blindage externe sous le collier de terre. Le câble ne doit pas être dénudé et doit cheminer aussi près que possible des bornes de la carte de commande. Pour les câbles de signaux analogiques, vous devez aussi mettre à la terre les blindages doubles et le fil de terre sur la borne SCR1. Fixez mécaniquement les câbles aux colliers situés sous l'unité de commande.
3. Les câbles doivent cheminer comme indiqué sur la figure.
4. Raccordez les conducteurs aux bornes appropriées de la carte de commande et serrez à 0,5...0,6 Nm.
5. Fixez tous les câbles de commande sur les colliers de câble fournis.

Raccordement des signaux d'E/S (préréglages)

Le schéma suivant illustre les préréglages usine des signaux d'E/S du programme de commande Standard ABB.

Macroprogramme Standard ABB :

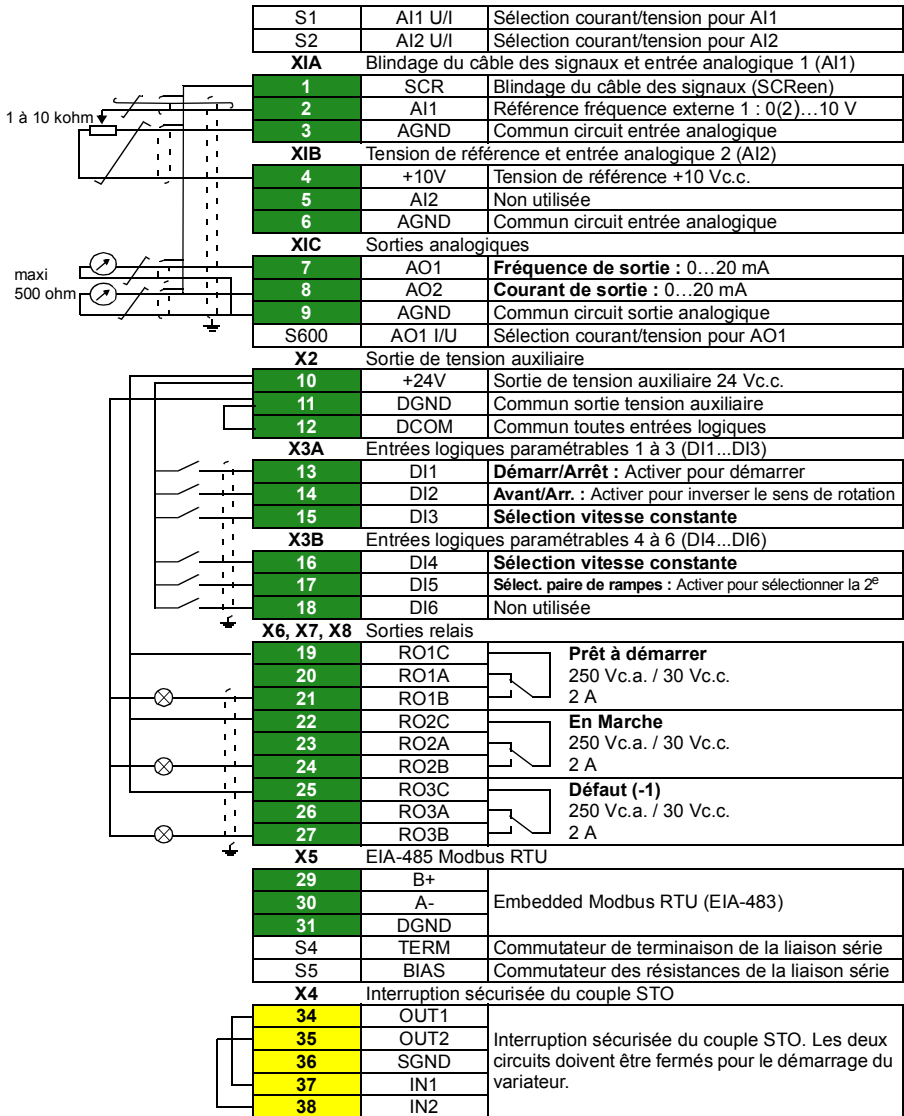

La capacité de charge totale de la sortie en tension auxiliaire +24V (X2:10) s'élève à 6,0 W (250 mA / 24 V).

Section des fils : 0,14...2,5 mm²(bornes +24V, DGND, DCOM, DI, AI, AOO, AGND, RO, STO)

Couples de serrage : 0,5...0,6 Nm

Installation des modules optionnels (si présents)

Cf. chapitre *Electrical installation* du manuel anglais *ACS580-01 user's manual* (3AUA0000076333).

Vérification de la compatibilité avec les réseaux en schéma IT (neutre isolé ou impédant) ou TN (mise à la terre asymétrique)



ATTENTION ! Il est interdit de raccorder un variateur équipé du filtre RFI interne sur un réseau en schéma IT (neutre isolé ou impédant) [plus de 30 ohm]) ou en schéma TN (mise à la terre asymétrique).

FR

Si vous raccordez le variateur sur un réseau en schéma IT (neutre isolé ou impédant) ou TN (mise à la terre asymétrique), débranchez les filtres RFI avant de raccorder le variateur au réseau. Pour la procédure détaillée, cf. chapitre *Electrical installation* du manuel anglais *ACS580-01 user's manual* (3AUA0000076333).

Remise en place du capot

Cf. figure [G](#).

1. Positionnez le capot sur boîtier d'entrée des câbles.
2. Serrez les deux vis restantes à l'aide d'un tournevis.
3. Remontez le capot du module. Insérez les deux languettes du capot dans les emplacements correspondants du châssis puis appuyez sur le capot.
4. Serrez les deux vis restantes à l'aide d'un tournevis.

Mise en route











Ce chapitre décrit la mise en route du variateur à l'aide de l'assistant de première mise en route de la micro-console intelligente.









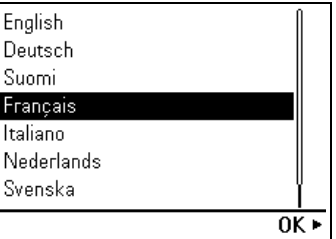

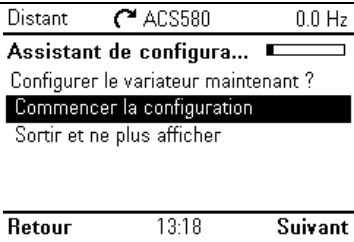

















Pour une description complète du firmware (fonctions, paramètres et localisation des défauts), cf. manuel anglais *ACS580-01 user's manual* (3AUA0000076333). Pour en savoir plus sur les micro-console intelligentes, cf. manuel anglais *ACS-AP-x assistant control panels user's manual* (3AUA0000085685).

Avant de commencer

Vérifiez que le variateur a été monté conformément aux instructions de la section [Installation](#) page 57.

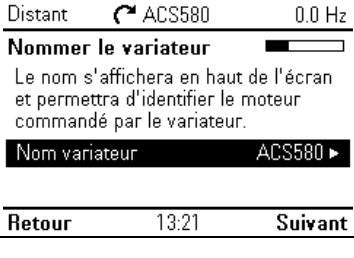
Mise en route avec l'assistant de la micro-console intelligente

Sécurité		
	Vous devez respecter les consignes de sécurité de la page 57 pendant la procédure de mise en route.	
<input type="checkbox"/>	Vérifiez que l'installation de l'appareil est correcte.	
<input type="checkbox"/>	Vérifiez que le moteur peut être démarré en toute sécurité. Vous devez désaccoupler la machine entraînée si elle risque d'être endommagée en cas d'erreur de sens de rotation du moteur.	
Conseils d'utilisation de la micro-console intelligente		
<p>Les deux commandes en bas de l'écran (Options et Menu sur la figure de droite) représentent les fonctions des deux touches  et  situées sous l'écran. Les commandes des touches de fonction varient selon le contexte.</p> <p>Les touches , ,  et  servent, selon la vue active, à déplacer le curseur et/ou à régler les valeurs.</p> <p>La touche  ouvre une page d'aide contextuelle.</p>		
1 – Réglages avec l'assistant de première mise en route : langue, date & heure et valeurs nominales du moteur		
<input type="checkbox"/>	<p>Gardez les données de la plaque signalétique du moteur à portée de main.</p> <p>Mettez le variateur sous tension.</p>	
<input type="checkbox"/>	<p>L'assistant de première mise en route vous guide pour la configuration initiale.</p> <p>L'appareil démarre automatiquement. Attendez jusqu'à ce que la micro-console affiche l'écran illustré à droite.</p> <p>Pour sélectionner la langue de votre choix, mettez-la en surbrillance et enfoncez la touche  (OK).</p>	

<input type="checkbox"/> Mettez le message Commencer la configuration en surbrillance (s'il ne l'est pas déjà) et enfoncez  (Suivant).	 <p>Distant  ACS580 0.0 Hz</p> <p>Assistant de configura... </p> <p>Configurer le variateur maintenant ?</p> <p>Commencer la configuration</p> <p>Sortir et ne plus afficher</p> <hr/> <p>Retour 13:18 Suivant</p>
<input type="checkbox"/> Réglez la date, l'heure et les formats d'affichage de la date et de l'heure. <ul style="list-style-type: none"> • Pour modifier une ligne en surbrillance, enfoncez la touche . • Faites défiler le contenu de l'affichage avec les touches  et . <p>Pour passer à l'écran suivant, appuyez sur  (Suivant).</p>	 <p>Distant  ACS580 0.0 Hz</p> <p>Date & Heure </p> <p>Saisissez l'heure et la date du jour.</p> <p>Date 06.08.2013 </p> <p>Heure 13:18:07 </p> <p>Format date jour.mois.année </p> <p>Format heure 24 heures </p> <hr/> <p>Retour 13:18 Suivant</p>
<input type="checkbox"/> En mode Edition : <ul style="list-style-type: none"> • Déplacez le curseur vers la droite ou la gauche avec les touches  et . • Ajustez la valeur avec  et . • Enfoncez  (Sauvegarder) pour sauvegarder votre réglage ou  (Annuler) pour annuler les modifications et revenir à l'écran précédent. 	 <p>Distant  ACS580 0.0 Hz</p> <p>Date</p> <p>Jour Mois Année</p> <p>06.08.2013</p> <p>Mardi</p> <hr/> <p>Annuler 13:18 Sauvegarder</p>
<input type="checkbox"/> Pour donner un nom au variateur (qui s'affichera en haut), appuyez sur  . Si vous souhaitez conserver le nom pré-réglé (ACS580), passez directement à la configuration des valeurs nominales du moteur en enfonceant la touche  (Suivant). Pour savoir comment modifier un texte, cf. document anglais <i>ACS580-01 user's manual</i> (3AUA0000076333) ou <i>ACS-AP-x assistant control panels user's manual</i> (3AUA0000085685).	 <p>Distant  ACS580 0.0 Hz</p> <p>Nommer le variateur </p> <p>Le nom s'affichera en haut de l'écran et permettra d'identifier le moteur commandé par le variateur.</p> <p>Nom variateur ACS580 </p> <hr/> <p>Retour 13:21 Suivant</p>

Reportez-vous à la plaque signalétique du moteur pour régler les valeurs nominales du moteur. Vous devez autant que possible entrer les valeurs exactes de la plaque signalétique du moteur.

Exemple de plaque signalétique d'un moteur asynchrone :

ABB Motors									
3 ~ motor		M2AA 200 MLA 4							
IEC 200 M/L 55									
No									
Ins.cl. F					IP 55				
V	Hz	kW	r/min	A	cos φ	IA/IN	tE/s		
690 Y	50	30	1475	32,5	0.83				
400 D	50	30	1475	56	0.83				
660 Y	50	30	1470	34	0.83				
380 D	50	30	1470	59	0.83				
415 D	50	30	1475	54	0.83				
440 D	60	35	1770	59	0.83				
Cat. no 3GAA 202 001 - ADA									
6312/C3		6210/C3			180 kg				
IEC 34-1									

- Assurez-vous que les données moteur sont correctes. Les valeurs sont préréglées en fonction de la taille de l'appareil mais vous devez vérifier qu'elles correspondent bien au moteur.
Commencez par le courant nominal.
Les réglages du cos phi nominal et du couple nominal sont facultatifs.
Enfoncez  (**Suivant**) pour continuer.

Distant  ACS580 0.0 Hz

Valeurs nominales mot... 

Trouvez les valeurs sur la plaque signalétique du moteur et entrez-les ici:

Courant nominal moteur 1.8 A 

Tension nominale moteur 400.0 V 

Retour 13:21 **Suivant**

- Pour vérifier le sens de rotation, mettez **Rotation moteur** en surbrillance et appuyez sur  (**Suivant**).

Distant  ACS580 0.0 Hz



Essai sens de rotation ? 

Faire tourner le moteur pour vérifier le sens de rotation ?

Pas maintenant

Rotation moteur 

Retour 13:22 **Suivant**

- Commencez par passer en commande locale à l'aide de la touche . Lorsque le variateur est en commande locale, «Local» s'affiche en haut de l'écran.
Enfoncez ensuite la touche Start  de la micro-console pour démarrer le variateur.











Local  ACS580 0.0 Hz

Appuyez sur Start 

Attention! Tant que la configuration n'est pas finie, les sécurités ne sont pas activées et la vitesse moteur est limitée à 5 Hz.

Appuyez sur Start pour faire tourner

Retour 13:25

<input type="checkbox"/> Vérifiez le sens de rotation du moteur. S'il tourne en sens avant, mettez Oui, rotation en sens avant en surbrillance (si ce n'est pas déjà fait) et enfoncez  (Suivant) pour poursuivre. Dans le cas contraire, mettez Non, sens de rotation fixe en surbrillance et enfoncez  (Suivant) pour poursuivre.	<div style="border: 1px solid black; padding: 5px;"> <p>Local  ACS580 5.0 Hz</p> <p>Rotation en sens avant ? </p> <p>Avec «Non, sens de rotation fixe», le variateur inverse le sens de rotation, qui devient le «sens avant».</p> <p>Oui, rotation en sens avant</p> <p>Non, sens de rotation fixe</p> <hr/> <p>Retour 13:22 Suivant</p> </div>
<input type="checkbox"/> Pour sauvegarder les réglages effectués jusqu'à présent, sélectionnez Sauvegarde et enfoncez  (Suivant). Si vous ne voulez pas faire de sauvegarde, sélectionnez Pas maintenant puis enfoncez  (Suivant).	<div style="border: 1px solid black; padding: 5px;"> <p>Local  ACS580 0.0 Hz</p> <p>Sauvegarder ? </p> <p>Copie tous les réglages dans un fichier sur la micro-console. Pour restaurer une sauvegarde : Menu > Sauvegardes.</p> <p>Pas maintenant</p> <p>Sauvegarde</p> <hr/> <p>Retour 13:23 Suivant</p> </div>
<input type="checkbox"/> Les réglages sont effectués ; le variateur est prêt à fonctionner. Enfoncez la touche  (Fait) pour accéder à la vue Accueil .	<div style="border: 1px solid black; padding: 5px;"> <p>Local  ACS580 0.0 Hz</p> <p>Configuration terminée</p> <p>Variateur prêt à fonctionner.</p> <hr/> <p>Retour 13:23 Fait</p> </div>
<input type="checkbox"/> La vue Accueil , qui permet de visualiser les valeurs des signaux sélectionnés, s'affiche à l'écran.	<div style="border: 1px solid black; padding: 5px;"> <p>Local  ACS580 0.0 Hz</p> <div style="border: 1px solid black; padding: 2px; margin-bottom: 2px;"> <p>Frequence sortie 0.00</p> <p>Hz</p> </div> <div style="border: 1px solid black; padding: 2px; margin-bottom: 2px;"> <p>Courant moteur 0.00</p> <p>A</p> </div> <div style="border: 1px solid black; padding: 2px; margin-bottom: 2px;"> <p>Couple moteur % 0.0</p> <p>%</p> </div> <hr/> <p>Options 13:23 Menu</p> </div>

2 – Réglages supplémentaires : macroprogramme, rampes, limites, par ex.

- Vous pouvez régler l'ensemble des paramètres, tels que le macroprogramme, les rampes, les limites, etc., depuis le **Menu principal** : pour y accéder, enfoncez la touche  (**Menu**).
Pour en savoir plus, cf. procédure de mise en route dans le manuel anglais *ACS580-01 user's manual* (3AUA0000076333).

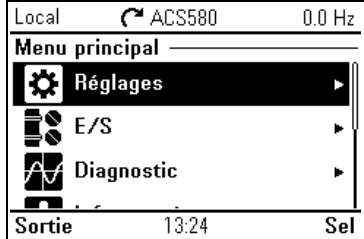

IT – Guida rapida a installazione e avviamento

Questa guida illustra brevemente come installare e avviare il convertitore di frequenza. Per le informazioni complete, consultare il *ACS580-01 user's manual* (www.abb.com/drives; selezionare *Document Library* e cercare il numero di documento 3AUA0000076333 [inglese]).

Installazione

Rispettare le norme di sicurezza



AVVERTENZA! Rispettare le seguenti norme di sicurezza. La mancata osservanza di queste norme può mettere in pericolo l'incolumità delle persone, con rischio di morte, e danneggiare le apparecchiature:

- L'installazione elettrica deve essere eseguita esclusivamente da elettricisti qualificati.
- Non operare sul convertitore, sul cavo motore o sul motore quando sono alimentati. Se il convertitore è già collegato all'alimentazione, disinserirla e attendere 5 minuti.
- Non lavorare sui cavi di controllo quando il convertitore o i circuiti di controllo esterni sono alimentati.
- Assicurarsi che i detriti generati da forature e smerigliature non si infiltrino nell'unità durante l'installazione.
- Assicurarsi che il pavimento sotto il convertitore e la parete dove è installato il convertitore siano non infiammabili.

IT

Ricondizionamento dei condensatori

Se il convertitore di frequenza è rimasto inutilizzato per un anno o più, è necessario ricondizionare i condensatori.

La data di fabbricazione si legge dal numero di serie riportato sull'etichetta identificativa del convertitore. Il formato del numero di serie è MYYWWRXXXX. YY e WW indicano rispettivamente l'anno e la settimana di produzione, nel modo seguente:

YY: 13, 14, 15, ... per 2013, 2014, 2015, ...

WW: 01, 02, 03, ... per settimana 1, settimana 2, settimana 3, ...

Per informazioni sul ricondizionamento dei condensatori, vedere *Converter module capacitor reforming instructions* (3BFE64059629 [inglese]), disponibile in Internet.

Selezione dei cavi di potenza

Dimensionare i cavi di potenza in base alle normative locali. I cavi devono essere adatti a condurre la corrente nominale indicata sull'etichetta identificativa del convertitore.

Raffreddamento

Vedere la tabella *I* e *II* a pag. 5 per i dati relativi alle perdite. Il range di temperatura operativa del convertitore, senza declassamento, è -15...+40 °C (+5...+104 °F). Non sono ammessi ghiaccio e condensa. Per le limitazioni al di sotto di 0 °C (+32 °F) e oltre +40 °C (+104 °F), vedere il capitolo *Technical data (Dati tecnici)* del ACS580-01 *user's manual* (3AUA0000076333 [inglese]).

Protezione del convertitore e del cavo di alimentazione di ingresso

Vedere la tabella *III*, *IV* e *V* a pag. 5 e 6 per i dati relativi ai fusibili.

Se si utilizzeranno fusibili gG, verificare sulla curva tempo-corrente del fusibile che il tempo di intervento del fusibile sia inferiore a 0.5 secondi. Attenersi alle normative locali.

Montaggio del convertitore di frequenza a parete

IT

Vedere le figure *A1* e *A2* a pag. 3.

Nota: è possibile utilizzare solo due viti, invece di quattro, per fissare la parte inferiore del convertitore.

Controllo dell'isolamento di cavo di ingresso, motore e cavo motore

Verificare che l'isolamento del cavo di ingresso sia conforme alle normative locali prima di collegarlo al convertitore di frequenza.

Controllare l'isolamento del cavo motore e del motore quando il cavo è scollegato dal convertitore. Misurare la resistenza di isolamento tra ogni conduttore di fase e il conduttore di protezione di terra (PE) con una tensione di misura di 1000 Vcc. La resistenza di isolamento dei motori ABB deve essere superiore a 100 Mohm (valore di riferimento a 25 °C o 77 °F). Per la resistenza di isolamento di altri motori, consultare le istruzioni del produttore.

Nota: la presenza di umidità all'interno dell'alloggiamento del motore riduce la resistenza di isolamento. In caso di umidità, asciugare il motore e ripetere la misurazione.

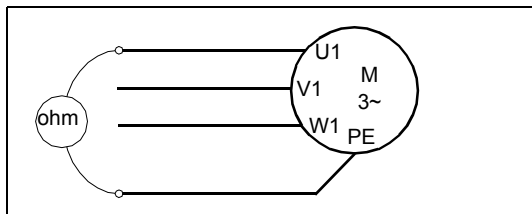

Collegamento dei cavi di potenza

Vedere le figure *B*, *C*, *D* e *E*. Utilizzare un cavo schermato di tipo simmetrico per il motore. Se la schermatura del cavo è l'unico conduttore PE per convertitore e motore, assicurarsi che abbia una conduttività sufficiente per il circuito di terra.

1. Applicare l'adesivo con il messaggio di avvertenza per tensione residua (nella lingua locale) vicino alla scheda di controllo.
2. Rimuovere la protezione sui morsetti dei cavi di potenza sganciando le clip e sollevando la protezione dai lati con un cacciavite (2a). Praticare i fori per l'ingresso dei cavi che saranno installati (2b).
3. Tagliare dei fori di dimensioni adeguate nei gommini. Far scivolare i gommini sui cavi. Preparare le estremità dei cavi come illustrato nella figura. Vengono mostrati due diversi tipi di cavi (3a, 3b). **Nota:** la schermatura dovrà essere messa a terra a 360°. Contrassegnare la treccia ottenuta con la schermatura come conduttore PE con i colori giallo e verde. Far passare i cavi attraverso i fori della piastra inferiore e inserire i gommini nei fori (cavo motore a destra e cavo di alimentazione di ingresso a sinistra).
4. Collegare il cavo motore:
 - Mettere a terra la schermatura a 360° sotto i morsetti di terra (4a).
 - Collegare la schermatura intrecciata del cavo al morsetto di terra (4b).
 - Collegare i conduttori di fase del cavo ai morsetti T1/U, T2/V e T3/W. Serrare le viti applicando le coppie indicate nella tabella *D* (4c).
5. Collegare il cavo di alimentazione di ingresso come spiegato al punto 4. Mettere a terra la schermatura a 360° sotto i morsetti di terra (5a). Collegare la schermatura intrecciata al morsetto di terra (5b) e i conduttori di fase ai morsetti L1, L2 e L3. Serrare le viti applicando le coppie indicate nella tabella *D* (5c).
6. Reinstallare la protezione EMC che separa i cavi di ingresso e di uscita.
7. Reinstallare la protezione sui morsetti di alimentazione.
8. Inserire i gommini inutilizzati nei fori della piastra passacavi.
9. Assicurare meccanicamente i cavi all'esterno dell'unità.
10. Mettere a terra la schermatura del cavo del motore sul lato motore. Per ridurre al minimo le interferenze da radiofrequenza, mettere a terra la schermatura del cavo motore a 360° in corrispondenza della piastra passacavi della morsettiera del motore.

Collegamento dei cavi di controllo

Vedere la figura [F](#). Mostra un esempio con un cavo dei segnali analogici e un cavo dei segnali digitali. Eseguire i collegamenti in base alla macro utilizzata. I collegamenti di default della macro ABB Standard sono illustrati nella sezione [Collegamenti di I/O di default](#) a pag. [75](#).

1. Praticare un foro di dimensioni idonee nel gommino e fare scivolare il gommino sul cavo. Far passare il cavo attraverso un foro della piastra inferiore e inserire il gommino nel foro.
2. Mettere a terra la schermatura esterna del cavo a 360° sotto il morsetto di terra. Il cavo non spellato deve rimanere il più possibile vicino ai morsetti della scheda di controllo. Per i cavi dei segnali analogici, mettere a terra anche le schermature dei doppi e il filo di terra in corrispondenza del morsetto SCR1. Fissare i cavi meccanicamente ai morsetti sotto l'unità di controllo.
3. Posare il cavo come mostrato nella figura.
4. Collegare i conduttori ai rispettivi morsetti della scheda di controllo e serrare applicando una coppia di 0.5...0.6 N·m.
5. Fissare tutti i cavi di controllo alle apposite fascette.

Collegamenti di I/O di default

Di seguito sono mostrati i collegamenti di I/O di default della macro ABB Standard.

Macro ABB Standard:

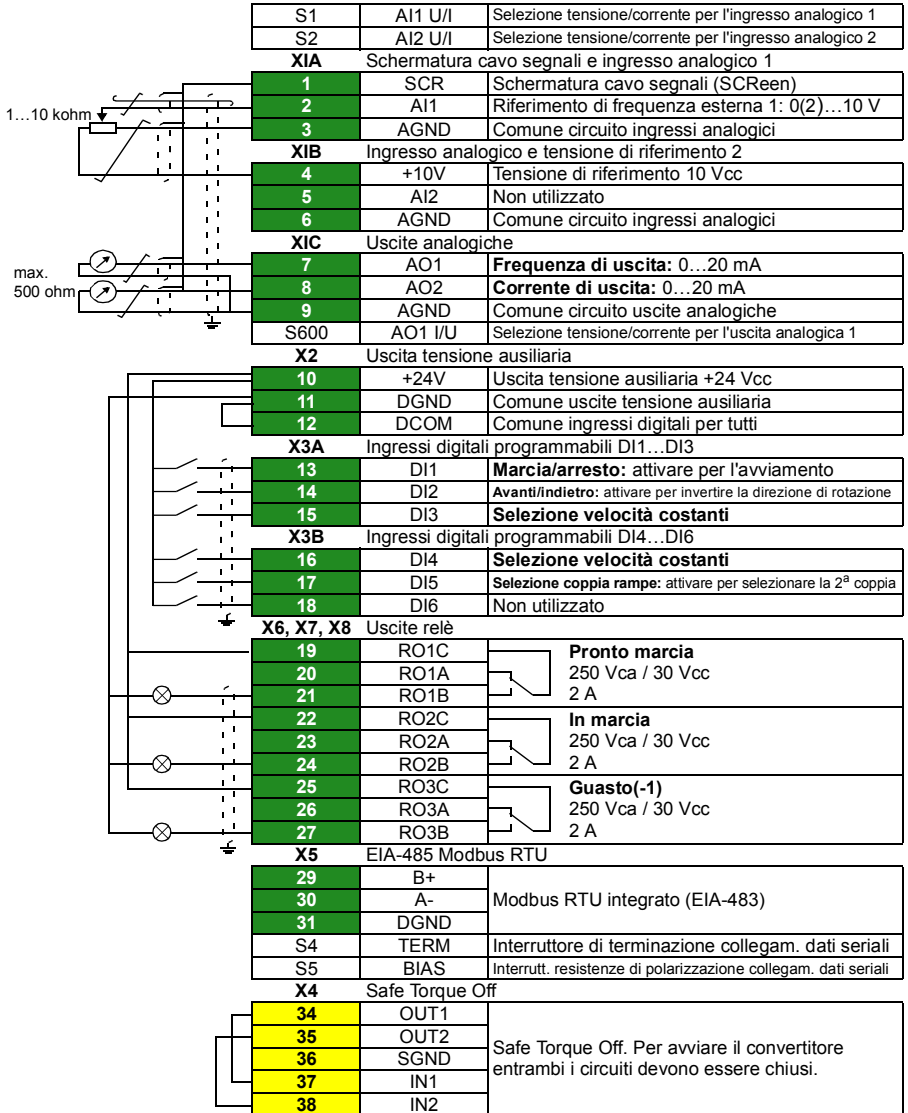

La capacità di carico totale dell'uscita di tensione ausiliaria +24V (X2:10) è 6.0 W (250 mA / 24 V).

Dimensioni fili: 0.14...2.5 mm²(morsetti +24V, DGND, DCOM DI, AI, AO, AGND, RO, STO)

Coppie di serraggio: 0.5...0.6 N·m

Installazione dei moduli opzionali, se presenti

Vedere il capitolo *Electrical installation* (Installazione elettrica) del *ACS580-01 user's manual* (3AUA0000076333 [inglese]).

Verifica della compatibilità con sistemi IT (senza messa a terra) e sistemi TN con una fase a terra



AVVERTENZA! Non installare il convertitore di frequenza con il filtro EMC interno collegato in sistemi IT (sistemi di alimentazione senza messa a terra o con messa a terra ad alta resistenza [oltre 30 ohm]) né in sistemi TN con una fase a terra.

IT

Se il convertitore deve essere collegato a sistemi IT (senza messa a terra) o sistemi TN con una fase a terra, scollegare i filtri EMC prima di collegare il convertitore alla rete di alimentazione. Per le istruzioni, vedere il capitolo *Electrical installation* (Installazione elettrica) del *ACS580-01 user's manual* (3AUA0000076333 [inglese]).

Reinstallazione dei coperchi

Vedere la figura [G](#).

1. Installare il coperchio della cassetta di ingresso dei cavi.
 2. Serrare le due viti di fermo con un cacciavite.
 3. Reinstallare il coperchio del modulo. Inserire le linguette in alto sul coperchio nelle apposite fessure sull'alloggiamento e premere il coperchio.
 4. Serrare le due viti di fermo con un cacciavite.
-

Avviamento

Questo capitolo descrive come avviare il convertitore di frequenza utilizzando la funzione di assistenza al primo avviamento sul pannello di controllo Assistant.

La documentazione completa del firmware del convertitore (caratteristiche dei programmi, parametri e risoluzione dei guasti) è contenuta nel *ACS580-01 user's manual* (3AUA0000076333 [inglese]). Per ulteriori informazioni sui pannelli Assistant, vedere *ACS-AP-x assistant control panels user's manual* (3AUA0000085685 [inglese]).

Prima di iniziare

Verificare che il convertitore sia stato installato come descritto nella sezione [Installazione](#) a pag. 71.

Avviamento con la funzione di assistenza del pannello Assistant



Sicurezza







Rispettare le norme di sicurezza riportate a pag. 71 durante la procedura di avviamento.

- Controllare l'installazione.
- Controllare che l'avviamento del motore non determini situazioni di pericolo.
Disaccoppiare la macchina comandata qualora vi sia rischio di danni in caso di errata direzione di rotazione.

Come utilizzare il pannello di controllo Assistant

I due comandi in basso sullo schermo (nella figura a destra, **Opzioni e Menu**) corrispondono alle funzioni dei due tasti software  e  posizionati sotto il display. I comandi assegnati ai tasti software variano in base al contesto.

Utilizzare i tasti , ,  e  per spostare il cursore e/o modificare i valori in base alla visualizzazione attiva.

Il tasto  richiama una pagina di aiuti sensibili al contesto.









1 – Impostazioni guidate al primo avviamento: lingua, data e ora, valori nominali del motore

- Tenere a portata di mano i dati di targa del motore. Accendere il convertitore.

- La funzione di assistenza al primo avviamento guida l'utente durante il primo avviamento. L'avviamento inizia automaticamente. Attendere finché sul pannello di controllo non compare la schermata della figura a destra. Selezionare la lingua dell'interfaccia: evidenziarla e premere  (OK).

English
Deutsch
Suomi
Français
Italiano
Nederlands
Svenska

OK ►

<input type="checkbox"/> Evidenziare Inizia set-up (se non è già evidenziato) e premere  (Avanti).	
<input type="checkbox"/> Impostare data, ora e i relativi formati. <ul style="list-style-type: none"> • Per modificare la riga selezionata, premere . • Scorrere verso l'alto e verso il basso con i tasti  e . Passare alla schermata successiva premendo  (Avanti).	
<input type="checkbox"/> Per modificare i dati sullo schermo: <ul style="list-style-type: none"> • Per spostare il cursore a destra e a sinistra, premere  e . • Per modificare il valore, premere  e . • Premere  (Salva) per accettare la nuova impostazione o  (Annulla) per tornare alla schermata precedente senza effettuare modifiche. 	
<input type="checkbox"/> Premere  per dare un nome al convertitore, che comparirà in alto sullo schermo. Se non si desidera cambiare il nome di default (ACS580), passare direttamente all'impostazione dei valori nominali del motore premendo  (Avanti). Per informazioni sulla modifica dei testi, vedere il <i>ACS580-01 user's manual</i> (3AUA0000076333 [inglese]) o <i>ACS-AP-x assistant control panels user's manual</i> (3AUA0000085685 [inglese]).	

Per le seguenti impostazioni dei valori nominali del motore, fare riferimento ai dati riportati sulla targa del motore. Quando possibile, i valori devono essere inseriti esattamente come compaiono sulla targa del motore.

Esempio di targa di un motore a induzione (asincrono):

ABB Motors									
3 ~ motor		M2AA 200 MLA 4							
IEC 200 M/L 55									
No									
Ins.cl. F					IP 55				
V	Hz	kW	r/min	A	cos φ	I/AVIN	E/s		
690 Y	50	30	1475	32.5	0.83				
400 D	50	30	1475	56	0.83				
660 Y	50	30	1470	34	0.83				
380 D	50	30	1470	59	0.83				
415 D	50	30	1475	54	0.83				
440 D	60	35	1770	59	0.83				
Cat. no 3GAA 202 001 - ADA									
6312/C3		6210/C3			180 kg				
IEC 34-1									

- Controllare che i dati del motore siano corretti. I valori sono predefiniti sulla base del telaio del convertitore, ma è necessario verificare che corrispondano al motore.

Iniziare dalla corrente nominale del motore.

I valori di cosφ nominale e coppia nominale del motore sono facoltativi.

Premere  (**Avanti**) per continuare.

Remoto	ACS580	0.0 Hz
Valori nominali motore		
Inserire i valori riportati sulla targa del motore:		
Corrente nomin motore	1.8 A	
Tensione nomin motore	400.0 V	
Frequenza nomin motore	50.00 Hz	
Indietro	15:31	Avanti









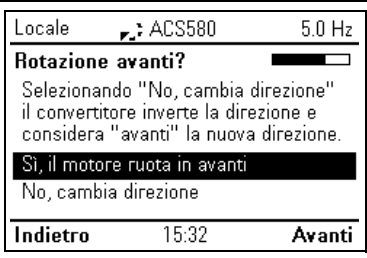

- Per eseguire la prova di rotazione del motore, evidenziare **Ruota il motore** e premere  (**Avanti**).

Remoto	ACS580	0.0 Hz
Prova direzione?		
Ruotare il motore per verificare la direzione?		
Non ora		
Ruota il motore		
Indietro	15:32	Avanti

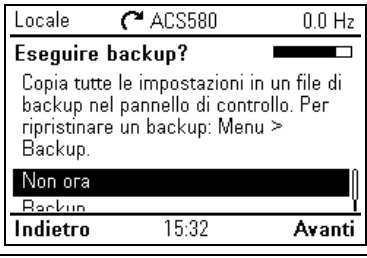
- Passare al controllo locale premendo il tasto . Quando è attivo il controllo locale, in alto sul display compare la scritta "Locale".

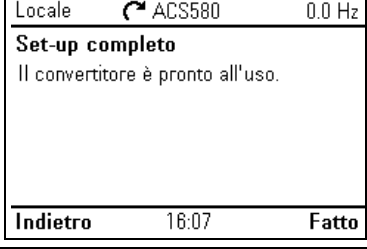
Quindi premere il tasto Start  sul pannello per avviare il convertitore.

Locale	ACS580	0.0 Hz
Premere Start		
Attenzione: durante il set-up le funzioni di sicurezza non sono attive e la velocità del motore è 5 Hz.		
Premere Start ora per avviare il motore e verificare la direzione di		
Indietro	15:32	

<input type="checkbox"/> Controllare la direzione di rotazione del motore. Se è "avanti", evidenziare (se non è già evidenziato) Si , il motore ruota in avanti e premere  (Avanti) per continuare. Se la direzione è "indietro", evidenziare No , cambia direzione e premere  (Avanti) per continuare.	
<input type="checkbox"/> Per eseguire un backup delle impostazioni fatte fin qui, selezionare Backup e premere  (Avanti). Se non si vuole eseguire un backup, selezionare Non ora e premere  (Avanti).	
<input type="checkbox"/> A questo punto il set-up è terminato e il convertitore di frequenza è pronto all'uso. Premere  (Fatto) per andare alla schermata Home .	
<input type="checkbox"/> Sul pannello compare la schermata Home da cui si esegue il monitoraggio dei segnali selezionati.	
2 – Altre impostazioni: macro, rampe, limiti...	
<input type="checkbox"/> Per effettuare altre impostazioni oltre a quelle descritte (ad esempio macro, rampe e limiti), andare al Menu principale premendo  (Menu). Per ulteriori informazioni, vedere la procedura di avviamento nel <i>ACS580-01 user's manual</i> (3AUA0000076333 [inglese]).	

NL – Beknopte installatie- en opstartgids

Deze gids geeft korte instructies voor het installeren en opstarten van de omvormer. Zie voor de volledige informatie: *AS580-01 user's manual* (www.abb.com/drives: Kies *Document Library* en zoek document nummer 3AUA0000076333 [Engels]).

Installatie

Volg de veiligheidsvoorschriften



WAARSCHUWING! Volg deze instructies. Indien u deze negeert, kan dit lichamelijk letsel of de dood tot gevolg hebben, of er kan schade aan de apparatuur ontstaan:

- Als u geen gekwalificeerd elektricien bent, voer dan geen elektrisch installatiewerkzaamheden uit.
- Voer nooit werkzaamheden uit aan de omvormer, de motorkabel of de motor als ze onder spanning staan. Als de omvormer al is aangesloten op het voedingsnet, ontkoppelt u de omvormer en wacht u 5 minuten.
- Voer geen werkzaamheden uit aan de besturingskabels als de omvormer of externe besturingscircuits onder spanning staan.
- Zorg bij de installatie dat er geen boor- of slijpafval in de omvormer binnendringt.
- Zorg er voor dat de vloer onder de omvormer en de wand waaraan de omvormer is gemonteerd onbrandbaar zijn.

NL

Controleer of condensatoren opnieuw geformeerd moeten worden

Als de omvormer een jaar of langer opgeslagen is geweest, moeten de condensatoren opnieuw geformeerd worden.

U kunt de fabricagedatum bepalen uit het serienummer, dat op het typeplaatje, bevestigd aan de omvormer, te vinden is. Het serienummer heeft het formaat MYYWWRXXXX. YY en WW bepalen als volgt het jaar en de week van fabricage:

YY: 13, 14, 15, ... voor 2013, 2014, 2015, ...

WW: 01, 02, 03, ... voor week 1, week 2, week 3, ...

Zie, voor informatie over het opnieuw formeren van de condensatoren, *Converter module capacitor reforming instructions* (3BFE64059629 [Engels]), dat op internet te vinden is.

Kies de vermogenskabels

Dimensioneer de vermogenskabels volgens de plaatselijke regelgeving om de nominale stroom te voeren die gegeven is op het typeplaatje van uw omvormer.

Zorg voor de koeling

Zie tabel *I* en *II* op pagina *5* voor de verliezen. Het toegestane bedrijfstemperatuurbereik van de omvormer zonder derating is -15 tot $+40$ °C ($+5$ tot $+104$ °F). Er is geen condensatie of vorst toegestaan. Voor beperkingen onder 0 °C ($+32$ °F) en boven $+40$ °C ($+104$ °F), zie het hoofdstuk *Technical data* in *ACS580-01 user's manual* (3AUA0000076333 [Engels]).

Beveilig de omvormer en de voedingskabel

Zie tabel *III*, *IV* en *V* op pagina *5* en *6* voor de zekeringen.

Als u gG-zekeringen gaat gebruiken, controleer dan via de tijd-stroom curve van de zekering dat de responstijd van de zekering onder de 0,5 seconden ligt. Volg de plaatselijke bepalingen.

NL Installeer de omvormer aan de wand

Zie de figuren *A1* en *A2* op pagina *3*.

Opmerking: U kunt alleen twee schroeven in plaats van vier gebruiken om het onderste gedeelte van de omvormer vast te zetten.

Controleer de isolatie van de ingangs- en motorkabels en van de motor

Controleer de isolatie van de ingangskabel volgens plaatselijke regelgeving alvorens de omvormer aan te sluiten op het voedingsnet.

Controleer de isolatie van de motorkabel en motor wanneer de kabel losgekoppeld is van de omvormer. Meet de isolatieweerstand tussen elke fasegeleider en de veiligheidsaardegeleider door een meetspanning van 1000 V DC te gebruiken. De isolatieweerstand van een ABB-motor moet hoger zijn dan 100 Mohm (referentiewaarde bij 25 °C of 77 °F). Voor de isolatieweerstand van andere motors moet u de instructies van de fabrikant raadplegen.

Opmerking: Vocht in de motorbehuizing zal de isolatieweerstand verlagen. Als u vocht vermoedt, moet u de motor drogen en de meting herhalen.

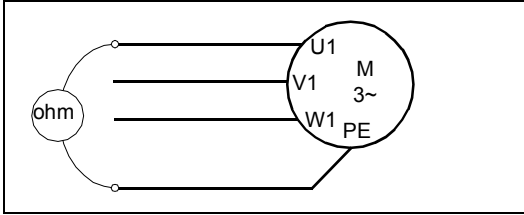

Sluit de vermogenskabels aan

Zie figuren *B*, *C*, *D* en *E*. Gebruik symmetrisch afgeschermd kabel voor de motorbekabeling. Als de kabelafscherming de enige PE-geleider voor de omvormer of motor is, zorg er dan voor dat deze voldoende geleidbaar is voor de PE.

1. Bevestig de waarschuwingssticker tegen restspanning in de plaatselijke taal vlak bij de stuurkaart.
2. Verwijder de afdekking op de vermogenskabelklemmen door de clips los te maken en de afdekking vanaf de zijkant met een schroevendraaier op te tillen (2a). Druk de gaten uit voor de te installeren kabels (2b).
3. Snijd geschikte gaten in de rubberen doorvoertules. Schuif de doorvoertules op de kabels. Maak de uiteinden van de kabels gereed zoals in de figuur geïllustreerd. Er worden twee verschillende types kabel getoond (3a, 3b).

Opmerking: De blote afscherming moet over 360 graden geaard worden. Markeer de pigtail die van de afscherming gemaakt is, als PE-geleider met een gele-en-groene kleur. Schuif de kabels door de gaten in de bodemplaat en bevestig de doorvoertules in de gaten (de motorkabel rechts en de voedingskabel links).
4. Sluit de motorkabel aan:
 - Aard de kabelafschermingen over 360 graden onder de aardklemmen (4a).
 - Sluit de getwiste afscherming van de kabel aan op de aardklem (4b).
 - Sluit de fasegeleiders van de kabel aan op de T1/U, T2/V en T3/W klemmen. Draai de schroeven vast tot het aanhaalmoment gegeven in tabel *D* (4c).
5. Sluit de voedingskabel aan zoals in stap 4. Aard de kabelafscherming over 360 graden onder de aardklemmen (5a). Sluit de getwiste afscherming aan op de aardklem (5b) en de fasegeleiders op de L1, L2 en L3 klemmen. Draai de schroeven vast tot het aanhaalmoment gegeven in tabel *D* (5c).
6. Installeer de EMC-afdekking die de ingangs- en uitgangsbekabeling scheidt.
7. Zet de afdekking op de vermogensklemmen terug.
8. Plaats de ongebruikte rubber doorvoertules in de gaten in de doorvoerplaat.

9. Zet de kabels buiten de unit mechanisch vast.
10. Aard de motorkabelafscherming aan de motorzijde. Voor minimale radiofrequentie-interferentie, dient de motorkabelafscherming over 360 graden geaard te worden bij de doorvoer van de motorklemmenkast.

Sluit de besturingskabels aan

Zie figuur *F*. Deze toont een voorbeeld met één analoge signaalkabel en één digitale signaalkabel. Maak de aansluitingen volgens de macro die u gebruikt. De standaard aansluitingen van de ABB standaardmacro zijn te zien in de sectie [Standaard I/O aansluitingen](#) op pagina [87](#).

1. Snij een voldoende groot gat in de rubberen doorvoertule en schuif de doorvoertule op de kabel. Schuif de kabel door een gat van de bodemplaat en maak de doorvoertule in het gat vast.
2. Aard de blote afscherming van de kabel over 360 graden onder de aardklem. Houd de kabel ongestript tot zo dicht mogelijk bij de klemmen van de besturingskaart. Aard bij analoge signaalkabels ook de afschermingen van het kabelpaar en de aardader bij de SCR1 klem. Zet de kabels mechanisch vast bij de klemmen onder de besturingsunit.
3. Leid de kabel zoals te zien in de figuur.
4. Sluit de geleiders aan op de betreffende klemmen van de stuurkaart en draai vast tot 0,5...0,6 N·m.
5. Bind alle besturingskabels aan de aanwezige kabelhouders.

Standaard I/O aansluitingen

Standaard I/O-aansluitingen van de ABB standaardmacro worden hieronder getoond.

ABB standaard macro:

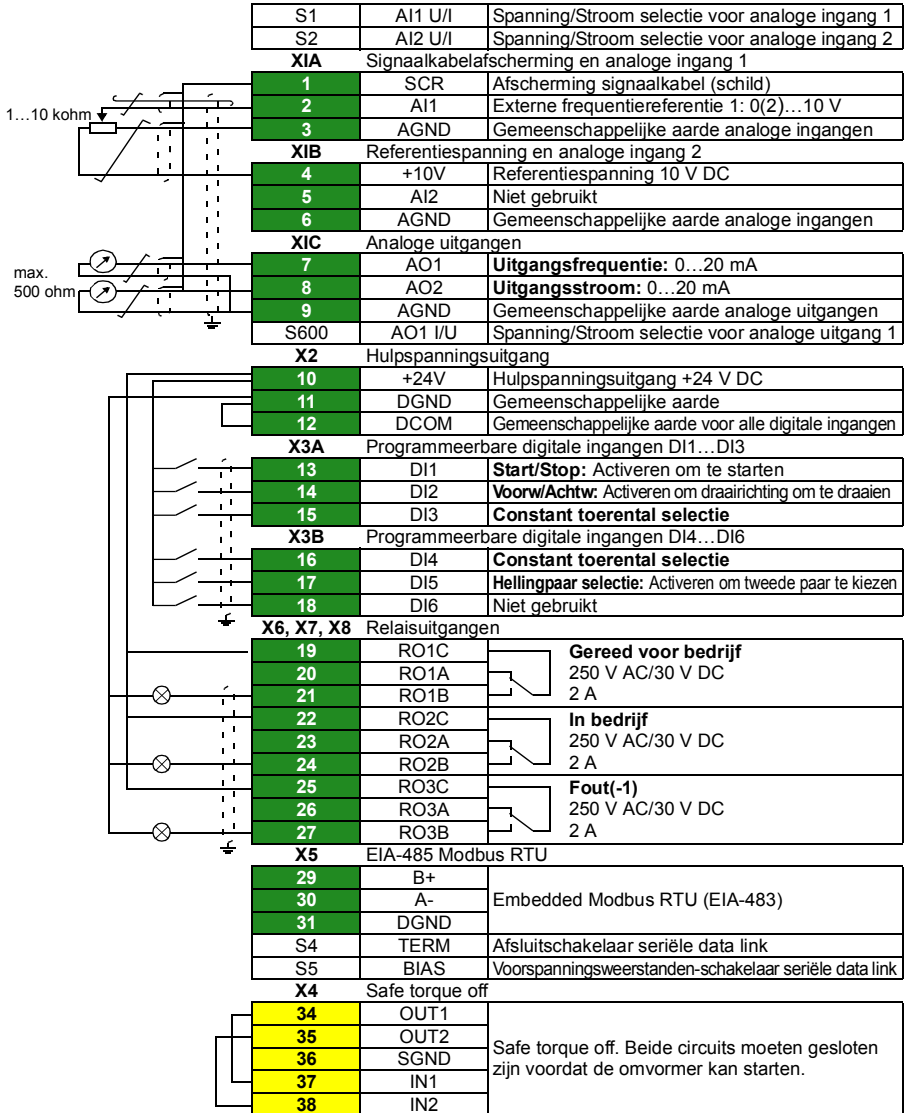

Totale belastingscapaciteit van de Hulpspanningsuitgang +24V (X2:10) is 6,0 W (250 mA / 24 V).

Ader-afmetingen: 0,14...2,5 mm²(klemmen +24V, DGND, DCOM, DI, AI, AOO, AGND, RO, STO)

Aanhaalmomenten: 0,5...0,6 N·m

Installeren van eventuele optionele modules

Zie het hoofdstuk *Electrical installation* in *ACS580-01 user's manual* (3AUA0000076333 [Engels]).

Controleer de compatibiliteit met IT (ongeaarde) en hoekgeaarde TN systemen



WAARSCHUWING! Installeer de omvormer niet met het interne EMC-filter aangesloten op een IT-systeem (een ongeaard vermogenssysteem of een over een hoge weerstand geaard [meer dan 30 ohm] vermogenssysteem) of op een corner-grounded TN-systeem.

Als u de omvormer aansluit op een IT (ongeaard) of een corner-grounded TN systeem, ontkoppel dan de EMC-filters vóóordat u de omvormer aansluit op het voedingsnetwerk. Zie, voor informatie om dit uit te voeren, het hoofdstuk *Electrical installation* in *ACS580-01 user's manual* (3AUA0000076333 [Engels]).

NL

Zet de kappen terug

Zie figuur G.

1. Zet de kap van het kabelingangsblok terug.
 2. Draai de twee bevestigingsschroeven vast met een schroevendraaier.
 3. Zet de modulekap terug. Plaats de lipjes aan de bovenkant van de kap in hun tegenhangers in de behuizing en druk dan de kap aan.
 4. Draai de twee bevestigingsschroeven vast met een schroevendraaier.
-

Opstarten











Dit hoofdstuk beschrijft het opstarten van de omvormer via de Eerste start assistent op het assistent-bedieningspaneel.









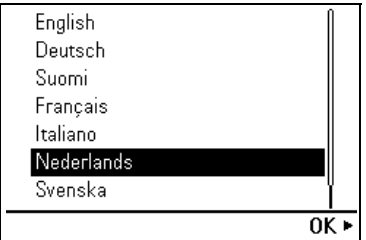



















De volledige documentatie van de omvormer-firmware: programmakenmerken, parameters en foutopsporing is te vinden in *AS580-01 user's manual* (3AUA0000076333 [Engels]). Zie, voor meer informatie over de assistent-panels, *ACS-AP-x assistant control panels user's manual* (3AUA0000085685 [Engels]).

Vóór het starten

Zorg er voor dat de omvormer geïnstalleerd is zoals beschreven in de sectie [Installatie](#) op pagina 83.





Opstarten met de Eerste start assistent op een assistentpaneel

Veiligheid	
 Volg de veiligheidsinstructies op pagina 83 tijdens de opstartprocedure.	
<input type="checkbox"/>	Controleer de installatie.
<input type="checkbox"/>	Controleer of het starten van de motor geen gevaar oplevert. Ontkoppel de aangedreven machine als er een risico van schade bestaat bij een eventueel verkeerde draairichting.
Tips bij het gebruik van het assistent-bedieningspaneel	
<p>De twee commando's onder aan het display (in de figuur rechts, Opties en Menu), tonen de functies van de twee softkeys  en  die zich onder het display bevinden. De commando's die aan de softkeys toegewezen zijn variëren afhankelijk van de context.</p> <p>Gebruik de toetsen , ,  en  om de cursor te bewegen en/of waarden te wijzigen, afhankelijk van het actieve scherm.</p> <p>De toets  toont een context-gevoelige help-pagina.</p>	
1 – Geleide instellingen van de Eerste start assistent: Taal, datum en tijd, en nominale waarden van de motor	
<input type="checkbox"/>	Houd de gegevens van het motortypeplaatje bij u. Schakel de voeding van de omvormer in.
<input type="checkbox"/>	<p>De Eerste start assistent leidt u door de eerste keer opstarten.</p> <p>Het opstarten begint automatisch. Wacht totdat het bedieningspaneel het scherm rechts hiernaast toont.</p> <p>Kies de taal die u wilt gebruiken door deze te markeren en op  (OK) te drukken.</p>
	

<p><input type="checkbox"/> Markeer Start set-up (indien nog niet gemarkeerd) en druk op  (Volgende).</p>	 <p>Afstand  ACS580 0.0 Hz</p> <p>Set-up Assistent </p> <p>Omvormer nu instellen?</p> <p>Start set-up</p> <p>Afsluiten & niet tonen bij inschak</p> <hr/> <p>Terug 13:44 Volgende</p>
<p><input type="checkbox"/> Stel de datum en tijd in, en ook de displayformats van datum en tijd.</p> <ul style="list-style-type: none"> • Ga naar het bewerkscherm van een gemarkeerde regel door op  te drukken. • Scroll door het scherm met  en . <p>Ga naar het volgende scherm door op  (Volgende) te drukken.</p>	 <p>Afstand  ACS580 0.0 Hz</p> <p>Datum & tijd </p> <p>Voer de huidige datum en tijd in.</p> <p>Datum 06.08.2013 </p> <p>Tijd 13:45:03 </p> <p>Toon datum als dag.maand.jaar </p> <p>Toon tijd als 24-uur </p> <hr/> <p>Terug 13:45 Volgende</p>
<p><input type="checkbox"/> In een bewerkscherm:</p> <ul style="list-style-type: none"> • Gebruik  en  om de cursor naar links en rechts te verplaatsen. • Gebruik  en  om de waarde te wijzigen. • Druk op  (Opslaan) om de nieuwe instelling te accepteren, of druk op  (Annuleren) om terug te gaan naar het vorige scherm zonder iets te wijzigen. 	 <p>Afstand  ACS580 0.0 Hz</p> <p>Datum</p> <p>Dag Maand Jaar</p> <p>06.08.2013</p> <p>Dinsdag</p> <hr/> <p>Annuleren 13:45 Opslaan</p>
<p><input type="checkbox"/> Om de omvormer een naam te geven die bovenaan wordt weergegeven drukt u op . Als u de standaard naam (ACS580) niet wilt wijzigen, gaat u meteen naar het instellen van de nominale waarden van de motor door op  (Volgende) te drukken.</p> <p>Zie, voor informatie over het bewerken van tekst, <i>ACS580-01 user's manual</i> (3AUA0000076333 [Engels]) of <i>ACS-AP-x assistant control panels user's manual</i> (3AUA0000085685 [Engels]).</p>	 <p>Afstand  ACS580 0.0 Hz</p> <p>Naamgeving van omvo... </p> <p>De naam staat bovenaan het scherm, zodat makkelijker te zien is welke motor door deze omvormer gestuurd wordt.</p> <p>Naam omvormer ACS580 </p> <hr/> <p>Terug 13:45 Volgende</p>

Raadpleeg het motortypeplaatje voor de volgende instellingen van de nominale waarden van de motor. Voer de waarden, indien mogelijk **exact** hetzelfde in als op het motortypeplaatje.

Voorbeeld van een typeplaatje van een (asynchrone) inductiemotor:

		ABB Motors					
3 ~ motor		M2AA 200 MLA 4					
		IEC 200 M/L 55					
		No					
		Ins.cl. F			IP 55		
V	Hz	kW	r/min	A	cos φ	IA/IN	t/s
690 Y	50	30	1475	32.5	0.83		
400 D	50	30	1475	56	0.83		
660 Y	50	30	1470	34	0.83		
380 D	50	30	1470	59	0.83		
415 D	50	30	1475	54	0.83		
440 D	60	35	1770	59	0.83		
Cat. no		3GAA 202 001 - ADA					
6312/C3		6210/C3		180 kg			
		IEC 34-1					

- Controleer dat de motorgegevens juist zijn. De waarden zijn voorgedefinieerd op basis van omvormergrootte, maar u dient te verifiëren dat ze overeenkomen met de motor.
Begin met de nominale motorstroom.
Nominale cosφ en nominaal koppel van de motor zijn optioneel.
Druk op  (**Volgende**) om door te gaan.

Afstand  ACS580 0.0 Hz

Nominale waarden mo... 

Kijk naar de waarden op het motortypeplaatje en voer ze hier in:

Nominale motorstroom 1.8 A 

Nominale motorspanning 400.0 V 

Nominale motorfrequentie 50.00 Hz 

Terug 13:45 **Volgende**

- Om de draairichtingstest uit te voeren, markeert u **Laat de motor draaien** en drukt u op  (**Volgende**).

Afstand  ACS580 0.0 Hz

Draairichting test? 

Motor laten draaien om richting te controleren?

Niet nu

Laat de motor draaien 

Terug 13:46 **Volgende**

- Schakel eerst over naar lokale bediening door op de  toets te drukken. Lokale besturing wordt aangegeven met de tekst "Lokaal" op de bovenste regel.
Druk daarna op de Start toets  op het paneel om de omvormer te starten.











Lokaal  ACS580 0.0 Hz

Druk op Start 

Waarschuwing: Totdat set-up voltooid is, zijn veiligheidsfuncties niet actief en is het motortoerental 5 Hz.

Druk nu op Start om de motor te laten draaien, en controleer daarna de

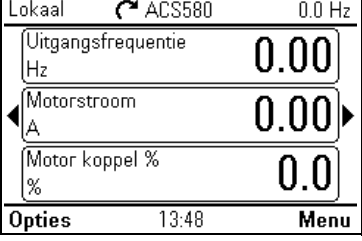
Terug 13:47

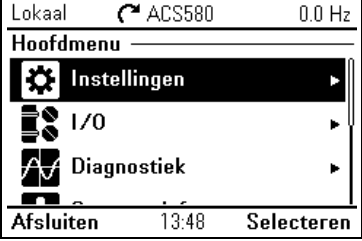
<p><input type="checkbox"/> Controleer de draairichting van de motor. Als deze voorwaarts is, markeer dan (indien nog niet gemarkeerd) Ja, motor draait voorwaarts en druk op  (Volgende) om door te gaan. Als de draairichting niet voorwaarts is, markeer dan Nee, leg richting vast en druk op  (Volgende) om door te gaan.</p>	
<p><input type="checkbox"/> Indien u een backup wilt maken van de instellingen tot nu toe gedaan zijn, selecteert u Backup en drukt u op  (Volgende). Indien u geen backup wilt maken, selecteert u Niet nu en drukt u op  (Volgende).</p>	
<p><input type="checkbox"/> De set-up is nu voltooid en de omvormer is gereed voor gebruik. Druk op  (Gereed) om naar het Home-scherm te gaan.</p>	
<p><input type="checkbox"/> Het Home-scherm, dat de waarden van de geselecteerde signalen monitort, wordt op het paneel getoond.</p>	
<p>2 – Aanvullende instellingen: bijvoorbeeld macro, hellingen, limieten</p>	
<p><input type="checkbox"/> Alle aanvullende instellingen, bijvoorbeeld macro, hellingen, en limieten kunt u uitvoeren vanuit het Hoofdmenu - druk op  (Menu) om naar het Hoofdmenu te gaan. Zie, voor meer informatie, de opstartprocedure in <i>ACS580-01 user's manual</i> (3AUA0000076333 [Engels]).</p>	

NL

SV – Snabbguide för installation och igångkörning

Denna handledning ger en översikt över installation och igångkörning av enheten. Fullständig information finns i *AS580-01 user's manual* (www.abb.com/drives: Välj *Document Library* och sök efter dokumentnummer 3AUA0000076333 [engelska]).

Installation

Följ säkerhetsinstruktionerna



WARNING! Följ dessa instruktioner. Om instruktionerna inte följs kan det orsaka personskador eller dödsfall eller skador på utrustningen:

- Elektriskt installationsarbete får endast utföras av person med nödig kännedom.
 - Arbeta inte med frekvensomriktaren, motorkabeln eller motorn när nätspänning är applicerad. Om frekvensomriktaren är ansluten till matningsspänning, vänta 5 minuter efter att den har fränskilts.
 - Arbeta aldrig med styrkablarna om frekvensomriktaren eller dess externa styrkretsar är spänningssatta.
 - Var noga med att inga borrh- eller slipspån kommer in i frekvensomriktaren i samband med installationen.
 - Var noga med att golvet under frekvensomriktaren och väggen där frekvensomriktaren är installerad är av icke brännbart material.
-

SV

Kontrollera om kondensatorerna måste reformeras

Om frekvensomriktaren förvarats i ett år eller längre måste kondensatorerna reformeras.

Tillverkningsdatumet kan fastställas med serienumren som finns på typbeteckningsetiketten på frekvensomriktaren. Serienumret är i formatet MAAVVRXXXX. AA och VV visar tillverkningsår och -vecka enligt följande:

AA: 13, 14, 15, ... för 2013, 2014, 2015, ...

VV: 01, 02, 03, ... för vecka 1, vecka 2, vecka 3, ...

Information om kondensatorformering finns i *Converter module capacitor reforming instructions* (3BFE64059629 [engelska]).

Anslutning av kraftkablar

Dimensionera kraftkablarna enligt lokala föreskrifter och den märkström som anges på frekvensomriktarens typbeteckningsetikett.

Kontrollera att kylningen är tillfredsställande

Se tabeller *I* och *II* på sidan *5* för förluster. Tillåtet driftstemperaturområde för frekvensomriktaren utan nedstämpling är -15 till +40 °C. Ingen kondensation eller frost tillåts. För begränsningar under 0 °C och över +40 °C, se kapitel *Technical data* i *ACS580-01 user's manual* (3AUA0000076333 [engelska]).

Skydda frekvensomriktaren och matningskabeln

Se tabeller *III*, *IV* och *V* på sidan *5* och *6* för säkringar.

Om gG-säkringar ska användas kontrollera via säkringens tid-strömkurva att säkringens utlösningstid understiger 0,5 sekunder. Följ lokala föreskrifter.

Installera frekvensomriktaren på vägg

Se *A1* och *A2* på sidan *3*.

Obs! Det går att använda bara två skruvar i stället för fyra för att montera den nedre delen av frekvensomriktaren.

Kontrollera isolationen hos nätkabel, motor och motorkabel

Kontrollera nätkabelns isolation enligt lokala föreskrifter innan den ansluts till frekvensomriktaren.

Kontrollera isolationen hos motorkabel och motor när kabeln är frånkopplad från frekvensomriktaren. Mät isolationsresistansen mellan varje fas och skyddsjordledare med en mätspänning på 1000 V DC. Isolationsresistansen hos en ABB-motor måste överskrida 100 Mohm (referensvärde vid 25 °C). För isolationsresistans hos andra motorer, se respektive tillverkares instruktioner.

Obs! Fukt inuti motorkapslingen minskar isolationsresistansen. Om fukt misstänks, torka motorn och upprepa mätningen.

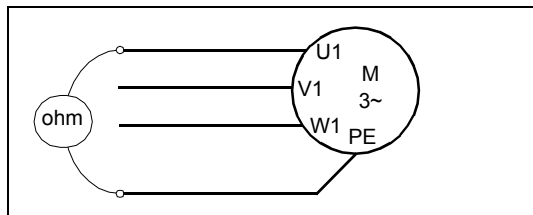

Anslut matningskablarna

Se figurerna *B*, *C*, *D* och *E*. Använd symmetrisk skärmad kabel för motoranslutning. Om kabelskärmen är den enda skyddsjordledaren för frekvensomriktaren eller motorn, se till att den har tillräcklig konduktivitet för skyddsjorden.

1. Sätt en varningsetikett för restspänningar på lokalt språk intill styrkortet.
2. Ta bort kåpan över kraftkabelanslutningarna genom att lossa klämmorna och lyfta kåpan uppåt med en skruvmejsel (2a). Öppna de förberedda hålen för kablarna som ska installeras (2b).
3. Skär lämpliga hål genom gummikragarna. För upp kragarna på kablarna. Förbered de inkommande ändarna av kablarna så som illustreras i figuren. Två olika kabeltyper visas (3a, 3b). **Obs!** Den frilagda skärmen ska jordas 360°. Markera stumpen från skärmen som PE-ledare med gul och grön färg. För kablarna genom hålen i bottenplattan och fäst kragarna i hålen (motorkabeln till höger och matningskabeln till vänster).
4. Skala motorkabeln:
 - Jorda skärmarna 360° runt om under jordningsöverfallen (4a).
 - Anslut den tvinnade kabelskärmänden till jordplintarna (4b).
 - Anslut kabelns fasledare till T1/U-, T2/V- och T3/W-anslutningarna. Dra åt skruvarna till det moment som anges i tabellen *D* (4c).
5. Anslut matningskabeln som i steg 4. Jorda skärmarna 360° runt om under jordningsöverfallen (5a). Anslut de sammantvinnade kabelskärmarna till jordplinarna (5b) och faskondensatorerna till L1-, L2- och L3-anslutningarna. Dra åt skruvarna till det moment som anges i tabellen *D* (5c).
6. Sätt på EMC-skärmen som separerar inkommande och utgående kablar.
7. Sätt tillbaka kåpan över kraftanslutningarna.
8. Sätt fast de oanvända gummikragarna på hålen i genomföringsplattan.
9. Fixera kablarna mekaniskt utanför enheten.
10. Jorda motorkabelskärmen vid motoränden. För att minimera den radiofrekventa strålningen, jorda frekvensomriktarens kabelskärm 360° runt om vid genomföringen i motorns anslutningslåda.

Anslut styrkablarna

Se figur [F](#). Den visar ett exempel med en analog signalkabel och en digital signalkabel. Gör anslutningarna enligt det makro som används. Standardanslutningarna för makrot ABB standard visas i avsnitt [Förvalda I/O-anslutningar](#) på sidan [99](#).

1. Skär ett lämpligt hål i gummikragen i anslutningslådans underdel och skjut upp kragen på kabeln. För kabeln genom ett hål i bottenplattan och fäst kragen i hålet.
2. Jorda den yttre kabelskärmen 360 grader under jordningsklämman. Kabeln ska vara skalad och kopplas samman så nära styrkortens plintar som möjligt. För analoga signalkablar, jorda även ledarparens skärmar och jordningskabeln vid SCR1-anslutningen. Fixera kablarna mekaniskt med klämmor under styrenheten.
3. Dra kablarna så som visas i figuren.
4. Anslut ledarna till sina respektive plintar på styrkortet och dra åt till 0,5...0,6 Nm.
5. Dra alla styrkablar till de medföljande kabelmonteringarna.

Förvalda I/O-anslutningar

Förvalda I/O-anslutningar för makrot ABB standard visas nedan.

Makrot ABB standard:

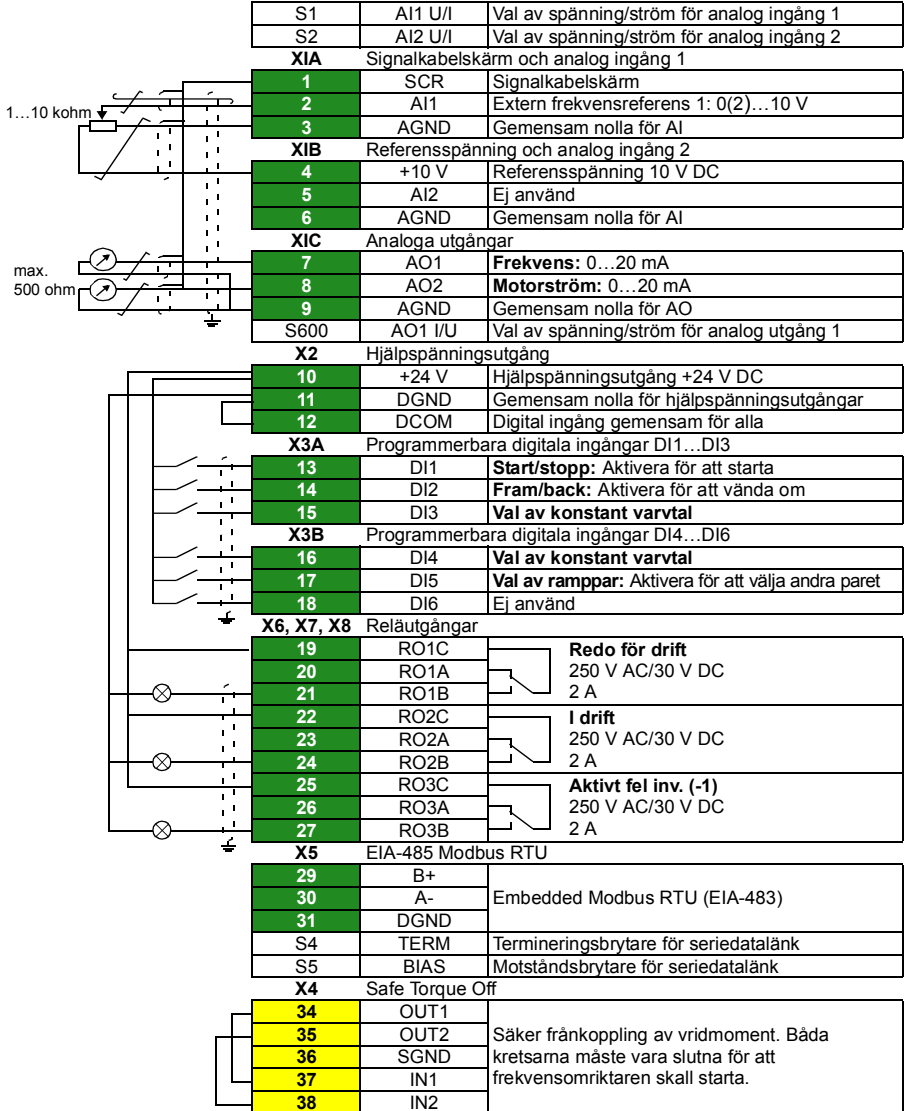

Total belastningskapacitet för hjälpspänningsutgång +24 V (X2:10) är 6,0 W (250 mA/24 V).

Ledardimensioner: 0,14...2,5 mm² (anslutningar +24V, DGND, DCOM, DI, AI, AOC, AGND, RO, STO)

Åtdragningsmoment: 0,5...0,6 Nm

Installerade tillvalsmoduler, i förekommande fall

Se kapitlet *Electrical installation* i *ACS580-01 user's manual* (3AUA0000076333 [engelska]).

Kontrollera kompatibilitet med IT-system (icke-direktjordade) och impedansjordade TN-system



WARNING! Installera inte frekvensomriktaren med det interna EMC-filtret anslutet till ett IT-system (ett ojordat matningssystem eller ett högresistivt [över 30 ohm] jordat matningssystem) eller ett impedansjordat TN-system.

Om du ansluter frekvensomriktaren till ett IT-system (ojordat) eller impedansjordat TN-system, koppla bort EMC-filtren innan frekvensomriktaren ansluts till matningsnätet. Mer information om hur det görs finns i kapitel *Electrical installation* i *ACS580-01 user's manual* (3AUA0000076333 [engelska]).

SV

Sätt tillbaka kåporna

Se figur G.

1. Sätt tillbaka kåpan på kabelgångslådan.
 2. Dra åt de två skruvarna med en skruvmejsel.
 3. Sätt tillbaka modul kåpan. Sätt flikarna på kåpans ovansida i motsvarande delar på kapslingen och tryck sedan på kåpan.
 4. Dra åt de två skruvarna med en skruvmejsel.
-

Idrifttagning











I det här kapitlet beskrivs idrifttagning av frekvensomriktaren med First start assistant på assistentmanöverpanelen.











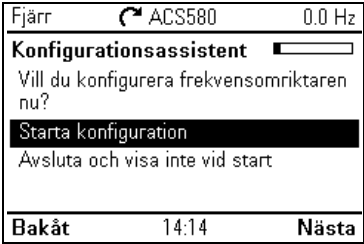

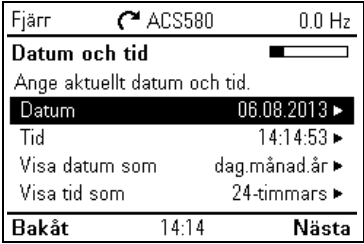

Komplett dokumentation med frekvensomriktarens systemprogramvara: programfunktioner, parametrar och felsökning finns i *AS580-01 user's manual* (3AUA0000076333 [engelska]). Mer information om assistentmanöverpaneler finns i *ACS-AP-x assistant control panels user's manual* (3AUA0000085685 [engelska]).

Innan du börjar

Se till att frekvensomriktaren har installerats enligt beskrivningen i avsnitt [Installation](#) på sidan [95](#).

Idrifttagning med Uppstartsassistenten på assistentmanöverpanelen

Säkerhet	
 Följ säkerhetsinstruktionerna på sidan 95 under igångkörsproceduren.	
<input type="checkbox"/>	Kontrollera installationen.
<input type="checkbox"/>	Kontrollera att det inte medför fara om motorn startas. Koppla bort den drivna utrustningen om det finns risk för skada på grund av felaktig rotationsriktning.
Tips för användning av assistentmanöverpanelen	
<p>De två kommandona längst ned på displayen (i figuren till höger, Alternativ och Meny), visar funktionerna för de två funktionstangenterna  och  nedanför displayen. Funktionstangenternas funktioner beror på aktuellt sammanhang.</p> <p>Använd tangenterna , ,  och  för att flytta markören och/eller ändra värdena beroende på den aktiva vyn.</p> <p>Tangenten  visar en sammanhållningskänslig hjälpsida.</p>	
1 – Inställningar med Uppstartsassistenten: Språk, datum och tid och motorns märkvärden	
<input type="checkbox"/>	Ha motorns märkskyltdata till hands. Spänningssätt frekvensomriktaren.
<input type="checkbox"/>	Uppstartsassistenten leder dig genom den första idrifttagningen. Idrifttagningen startar automatiskt. Vänta tills manöverpanelen går in i vyn som visas till höger. Välj det språk du vill använda genom att markera det och trycka på  (OK).
	

<input type="checkbox"/> Markera Starta konfiguration (om det inte redan är markerat) och tryck på  (Nästa).	
<input type="checkbox"/> Ange datum och tid och visningsformat för dem. <ul style="list-style-type: none"> • Gå till redigeringsvy för en markerad rad genom att trycka på . • Rulla i vyn med  och . Gå till nästa vy genom att trycka på  (Nästa).	
<input type="checkbox"/> I en redigeringsvy: <ul style="list-style-type: none"> • Använd  och  för att flytta markören åt vänster och höger. • Använd  och  för att ändra värdet. • Tryck på  (Spara) för att acceptera den nya inställningen eller tryck på  (Avbryt) för att gå tillbaka till föregående vy utan att göra ändringar. 	
<input type="checkbox"/> Tryck på  för att ange ett namn för frekvensomriktaren som visas längst upp. Om du inte vill ändra standardnamnet (ACS580) fortsätter du direkt till konfigurationen av motors märkvärden genom att trycka på  (Nästa). Information om redigering av text finns i ACS580-01 user's manual (3AUA0000076333 [engelska]) och ACS-AP-x assistant control panels user's manual (3AUA0000085685 [engelska]).	

Se motorns märkskylt för följande motordata. I mån av möjlighet, mata in värdena exakt så som de anges på motorns märkskylt.

Exempel på märkskylt på en asynkronmotor:





V		Hz	kW	r/min	A	cos ϕ	IA/IN	tE/s
690 Y	50	30	1475	32.5	0.83			
400 D	50	30	1475	56	0.83			
660 Y	50	30	1470	34	0.83			
380 D	50	30	1470	59	0.83			
415 D	50	30	1475	54	0.83			
440 D	60	35	1770	59	0.83			

Kontrollera att motordata är korrekta. Värdena är fördefinierade baserat på frekvensomriktarens storlek men du bör verifiera att de motsvarar motorn.

Starta med motorns märkström.

Motorns nominella cos ϕ och märkmoment är tillval.

Tryck på  (**Nästa**) för att fortsätta.

Fjärr	 ACS580	0.0 Hz
Motorbörvärden		
Ange värdena, som finns på motorns namnplåt, här:		
Motor nom ström	1.8 A	
Motor nom spänn	400.0 V	
Motor nom frekv	50.00 Hz	
Bakåt	14:15	Nästa











Gör riktningstestet genom att markera **Rotera motorn** och trycka på  (**Nästa**).

Fjärr	 ACS580	0.0 Hz
Riktningstest?		
Rotera motorn för att kontrollera riktningen?		
Inte nu		
Rotera motorn		
Bakåt	14:16	Nästa

Växla först till lokal styrning genom att trycka på tangenten . Lokal styrning indikeras av texten "Lokal" på displayens övre del.

Tryck sedan på Starttangenten  på panelen för att starta frekvensomriktaren.

Lokal	 ACS580	0.0 Hz
Tryck på Starta		
Varning! Innan konfigurationen är klar är inte säkerhetsfunktionerna aktiva och varvtalet är 5 Hz.		
Tryck på Start nu för att rotera motorn och kontrollera roteringsriktningen.		
Bakåt	14:16	

<input type="checkbox"/>	<p>Kontrollera motorns rotationsriktning.</p> <p>Om den roterar framåt, markera Ja, motorn roterar framåt (om det inte redan är markerat) och tryck på  (Nästa) för att fortsätta.</p> <p>Om riktningen inte är framåt, markera Nej, ändra riktning och tryck på  (Nästa) för att fortsätta.</p>	<p>Lokal  ACS580 5.0 Hz</p> <p>Är detta framåt? </p> <p>Om du väljer Nej, ändra riktning ändrar frekvensomriktaren riktning och sätter etiketten "framåt" på den nya riktningen.</p> <p>Ja, motorn roterar framåt</p> <p>Nej, ändra riktning</p> <p>Bakåt 14:16 Nästa</p>
<input type="checkbox"/>	<p>Om du vill säkerhetskopiera inställningarna som gjorts hittills, välj Säkerhetskopiera och tryck på  (Nästa).</p> <p>Om du inte vill göra en säkerhetskopiera, välj Inte nu och tryck på  (Nästa).</p>	<p>Lokal  ACS580 0.0 Hz</p> <p>Skapa en säkerhetsko... </p> <p>Kop. alla inst. till en säkerhetskop. i manöverpanelen. Återst. en säkerhetskopiering: gå till Meny > Säkerhetskopiering.</p> <p>Inte nu</p> <p>Säkerhetskopiera</p> <p>Bakåt 14:16 Nästa</p>
<input type="checkbox"/>	<p>Konfigurationen är klar och frekvensomriktaren är klar att användas.</p> <p>Tryck på  (Klart) för att öppna startvyn.</p>	<p>Lokal  ACS580 0.0 Hz</p> <p>Konfigurationen är klar</p> <p>Frekvensomriktaren är klar att användas.</p> <p>Bakåt 14:16 Klart</p>
<input type="checkbox"/>	<p>Startvyns övervakning av värdena för valda signaler visas på panelen.</p>	<p>Lokal  ACS580 0.0 Hz</p> <p>Frekvens Hz 0.00</p> <p>Motorström A 0.00</p> <p>Motor moment % 0.0</p> <p>Alternativ 14:18 Meny</p>

2 – Ytterligare inställningar: till exempel makro, ramper, gränser

- Gör ytterligare inställningar, till exempel makro, ramper och gränser från **huvudmenyn** genom att trycka på  (**Meny**) för att öppna **huvudmenyn**.
För mer information, se idrifttagningsproceduren i *ACS580-01 user's manual* (3AUA0000076333 [engelska]).

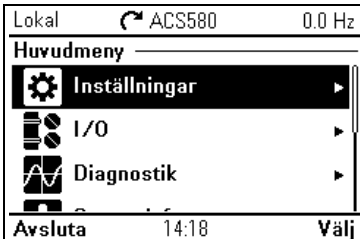

Further information

Product and service inquiries

Address any inquiries about the product to your local ABB representative, quoting the type designation and serial number of the unit in question. A listing of ABB sales, support and service contacts can be found by navigating to www.abb.com/searchchannels.

Product training

For information on ABB product training, navigate to www.abb.com/drives and select *Training courses*.

Providing feedback on ABB Drives manuals

Your comments on our manuals are welcome. Go to www.abb.com/drives and select *Document Library – Manuals feedback form (LV AC drives)*.

Document library on the Internet

You can find manuals and other product documents in PDF format on the Internet. Go to www.abb.com/drives and select *Document Library*. You can browse the library or enter selection criteria, for example a document code, in the search field.

Contact us

www.abb.com/drives

www.abb.com/drivespartners

3AXD50000007518 Rev A (MUL) 2013-09-02



3AXD50000007518A